

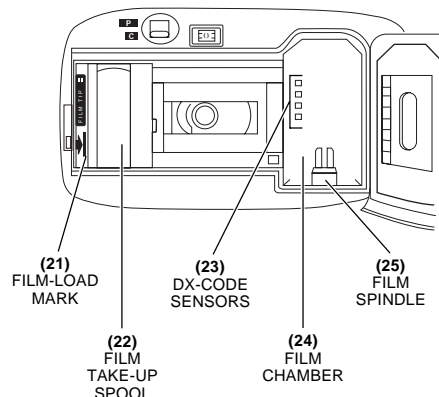

GETTING TO KNOW YOUR CAMERA

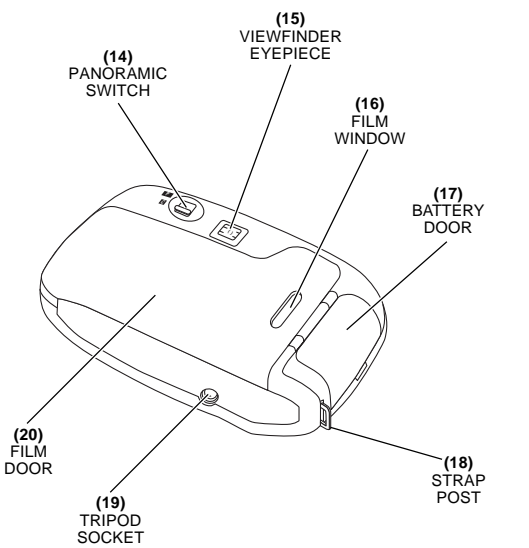

LCD PANEL

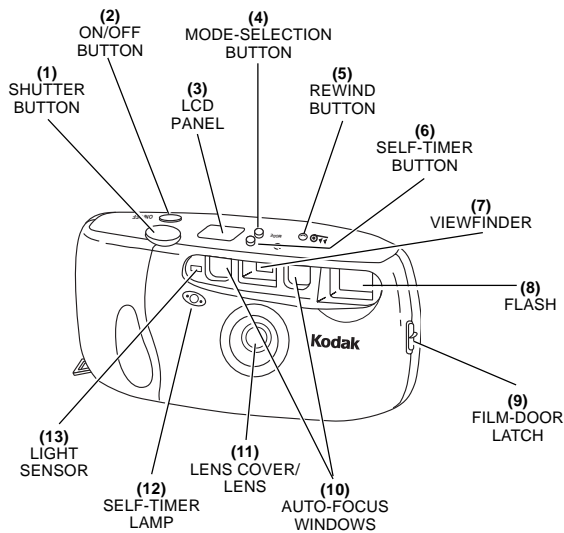
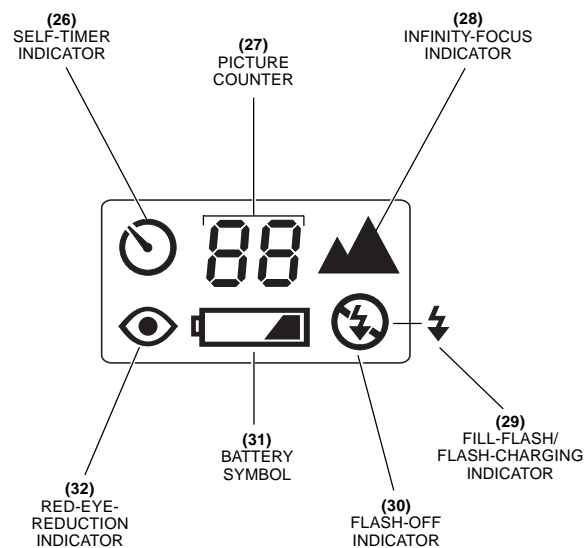

1 ATTACHING THE CAMERA STRAP

Thread the short loop of the strap under the Strap Post (18); pull the long loop through the short loop and pull it tight.

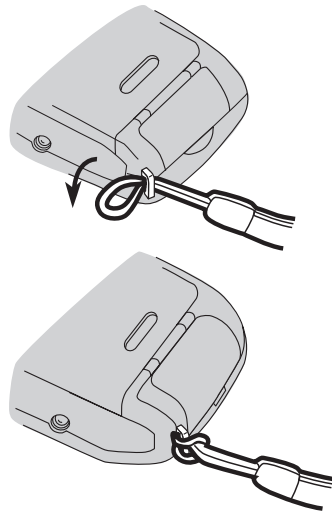

2 LOADING THE BATTERY

This camera uses a 3-volt lithium KODAK K123LA (or equivalent) Battery that supplies power for all camera operations.

NOTE: This camera automatically turns off after approximately 3 minutes to conserve battery energy.

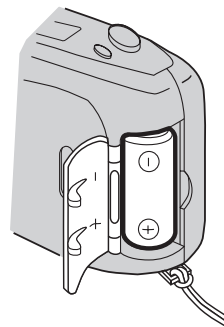
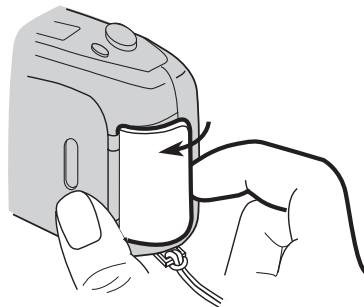

Battery Tips

- Keep a spare battery with you at all times. Lithium batteries perform consistently until they suddenly die.
- Read and follow all warnings and instructions supplied by the battery manufacturer.
- Keep batteries away from children.
- Do not try to take apart, recharge or short circuit the battery, or subject it to high temperature or fire.
- Store batteries in their original packaging prior to use.

Low-Battery Indicator

It's time to replace the battery when—

- the Battery Symbol (31) appears on the LCD Panel (3).
- the battery symbol on the LCD panel "blinks."
- none of the indicators appear on the LCD panel.

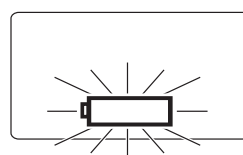
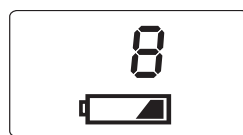

3 LOADING THE FILM

If in sunlight, turn your back to the sun and load the film in the shade of your body.

1. Slide the Film-Door Latch (9) down to open the Film Door (20).

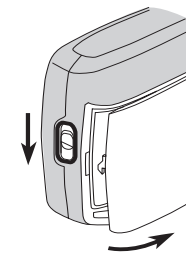

2. Insert the flat end of the film cartridge over the Film Spindle (25). Push the other end of the film cartridge down into the Film Chamber (24) until it snaps into place. **Do not force it into the film chamber.**

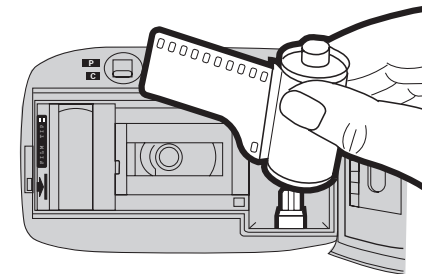

4 TAKING PICTURES

1. Press the On/Off Button (2) to turn the camera ON. When you turn the camera on, the lens cover automatically opens.

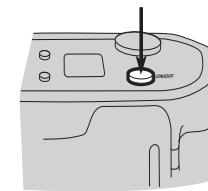

2. Hold the camera steady. **Be careful not to cover the flash, lens, and auto-focus windows with your fingers.**



3. Look through the Viewfinder Eyepiece (15) and center the auto-focus brackets on your subject. For a sharp picture, **stand at least 2.5 ft (0.8 m) from your subject.** When your subject is within 2.5 to 4 ft (0.8 to 1.2 m) from the camera, position the subject below the top format/panoramic indicators.

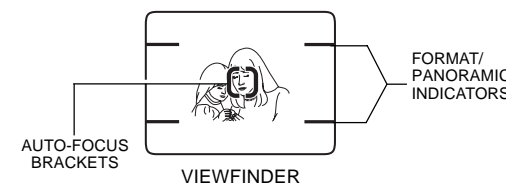

4. Gently press the Shutter Button (1) completely down to take the picture. The film automatically advances to the next frame.

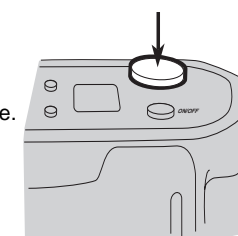

Taking Panoramic Pictures (without changing rolls of film, you can switch between the panoramic and normal formats)

The panoramic selection allows you to take wide-angle shots, such as large groups, football and baseball fields, landscapes, tall buildings, waterfalls, etc.

Note to Owners of the Quartz Date and Time Model: Date and time imprinting is not available in the panoramic format.

1. Slide the Panoramic Switch (14) from normal to the panoramic position. The Viewfinder (7) changes to show the selected field of view.

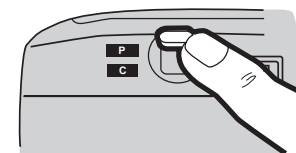

3. Pull out the film leader until the tip reaches the Film-Load Mark (21). Lay the film flat between the film-guide rails.

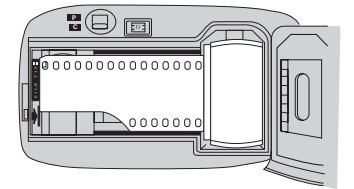

If the end of the film extends past the film-load mark, gently push the excess back into the cartridge.

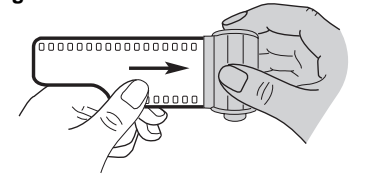

4. Close the film door. The film automatically advances to the first frame and the LCD Panel (3) displays "1." **Do not open the film door after you start taking pictures or you will ruin the film.**

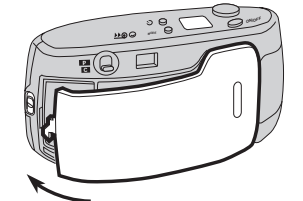

NOTE: If the Picture Counter (27) on the LCD Panel (3) blinks "0," the film is not loaded correctly. Open the film door and reload the film.

2. Compose your picture within the Viewfinder Eyepiece (15) and press the Shutter Button (1).

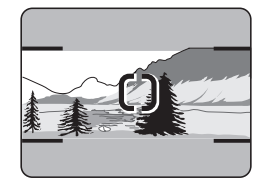

VIEWFINDER

3. Slide the panoramic switch down to return to the normal position.

Printing Panoramic Format Pictures:

If you took panoramic pictures on the entire roll of film, ask the processing-lab clerk to print the film only in the panoramic format. If there are panoramic and normal format pictures on the film, ask the clerk to print the film in both the normal and panoramic formats. (Normal format prints are 3 1/2 x 5 in. [88.9 x 127 mm] or 4 x 6 in. [102 x 152 mm], whereas panoramic format prints are 3 1/2 x 10 in. [88.9 x 254 mm].) You may want to consult the processing lab for development time and cost, and don't forget to check the optional panoramic box on the photofinishing envelope.

Using the Focus Lock

This camera automatically focuses on whatever is within the auto-focus brackets of the viewfinder eyepiece. If you want to take a picture with the subject positioned outside of the auto-focus brackets, use the auto-focus lock as follows:

1. Place the auto-focus brackets on the subject you want focused in the picture.

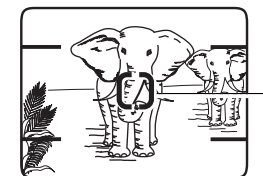

VIEWFINDER

2. Partially depress and hold the Shutter Button (1) to lock the focus.
3. While still partially depressing the shutter button, move the camera until your subject is where you want it within the Viewfinder Eyepiece (15).

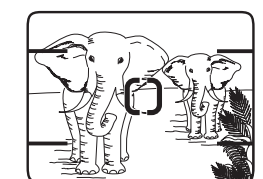

VIEWFINDER

4. Press the shutter button completely down to take the picture.

Continued on reverse side ▶

ENGLISH

Congratulations! And thank you for buying a KODAK CAMEO Camera. Your new compact, auto-focus 35 mm camera with motorized film advance and auto-film rewind, makes taking pictures easy. The camera uses any DX/DXN, 35 mm color or black-and-white print film with a speed of ISO 100, 200, 400, or 1000.

For warranty purposes, please keep your sales receipt as proof of the date of purchase.

SPECIFICATIONS

Type: Compact, auto-focus 35 mm camera

LCD Panel: Display indicators for red-eye reduction, fill-flash/flash-charging, flash-off, infinity-focus, self-timer, and the frame number and battery symbol

Lens: 28 mm, f/4.5; 3-element glass lens

Focus System: 4 zone active infrared AF system with focus lock; optional infinity-focus mode

Viewfinder: Reverse-Galilean with bright line field of view and AF aiming indicator; panoramic masking in panoramic mode

Film Speed: DX (ISO) 100 – 1000 for color or black-and-white print film

Focus Range: Daylight: 2.5 ft. (0.8 m) to infinity

Flash Unit: Electronic with ISO 100/21", guide number of 26 ft (8 m); flash automatically turns on at low-light levels

Aperture: f/13 – f/4.5

Shutter: 1/150 to 1.2 sec

Power Source: one 3-volt lithium KODAK K123LA (or equivalent) Battery

Dimensions: 4.9 x 2.7 x 1.3 in. (123.5 x 68.8 x 32.7 mm)

Weight: 6 oz. (170 g)

This device complies with part 15 of the FCC Rules. Operation is subject to the following two conditions: (1) this device may not cause harmful interference, and (2) this device must accept any interference received, including interference that may cause undesired operation.

NOTE: Your model camera has been tested and found to comply with the limits for a Class B digital device, pursuant to Part 15 of the FCC Rules. These limits provide reasonable protection against interference in residential use. The camera generates, uses and can radiate radio frequency energy and, if not used in accordance with the instructions, may cause interference to radio communications. There is no guarantee that interference will not occur. If this camera does cause interference to radio or television reception, which can be determined by turning the camera off and on, you may reduce the interference by the following:

- Reorient or relocate the receiving antenna.
- Increase the separation between the camera and the receiver.
- Consult the dealer or an experienced radio/television technician for help.

Changes or modifications not approved by the party responsible for compliance could void the user's authority to operate the equipment.

© Eastman Kodak Company, 1997

Consumer Imaging
EASTMAN KODAK COMPANY • Rochester, NY 14650



Pt. No. 8B9641

Kodak and Cameo are trademarks.

1-97
Printed in China.

4 TAKING PICTURES

(Continued)

Using the Self-Timer

When you want to include yourself in the picture, use the self-timer feature.

1. Use the Tripod Socket (19) to attach the camera to a tripod, or place the camera on another firm support.
2. Press the On/Off Button (2) to turn the camera ON.
3. Press the Self-Timer Button (6). The Self-Timer Indicator (26) appears on the LCD Panel (3) and the Self-Timer Lamp (12) glows red.

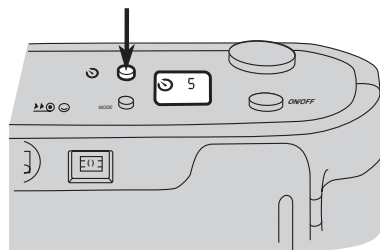

4. Compose your picture and press the Shutter Button (1). The self-timer lamp "blinks" approximately 10 seconds before the picture is taken. After you take the picture, the self-timer automatically turns off.

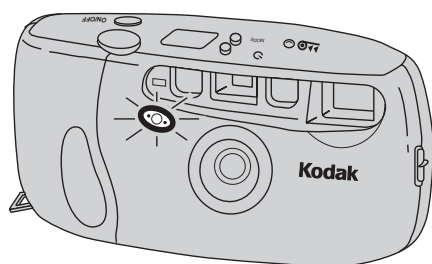

NOTE: If you want to stop the self-timer operation before the picture is taken, repress the self-timer button or turn the camera off.

Using the Infinity-Focus Mode

To capture sharp, distant scenery, use the infinity-focus mode.

1. Press the On/Off Button (2) to turn the camera ON.
2. Press the Mode-Selection Button (4) to select infinity focus. Make sure the Infinity-Focus Indicator (28) appears on the LCD Panel (3).

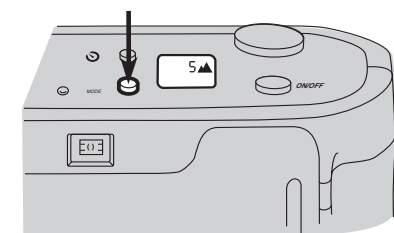

3. Press the Shutter Button (1) to take the picture.

NOTE: The camera automatically returns to the auto-flash/start position after you take the picture.

Tips for Better Pictures

- Keep your pictures simple. Move close enough to your subject so it fills the viewfinder **but not closer than 2.5 ft (0.8 m)**.
- Take pictures at the subject's level. Kneel down to take pictures of children and pets.
- Hold your camera vertically to capture tall, narrow subjects, such as a waterfall, skyscraper, or single person.
- Add interest to your picture by framing it with a tree branch, a window, or even the rails of a fence.
- Keep the sun behind you. This provides best subject illumination.

5 TAKING FLASH PICTURES

In dim light, such as indoors or outdoors in heavy shade or on dark overcast days, you need flash. Your camera features automatic flash that fires when you need it.

1. Press the On/Off Button (2) to turn the camera ON.
2. Keep the subject within the distance range for the speed of the film in your camera (see table below). **Be careful not to cover the flash, lens, and auto-focus windows with your fingers.**
3. Press the Shutter Button (1) **partway** down. If the Flash-Charging Indicator (29) on the LCD Panel (3) "blinks," the flash is not fully charged. Wait for the blinking to stop and the indicator to disappear before you take the picture.

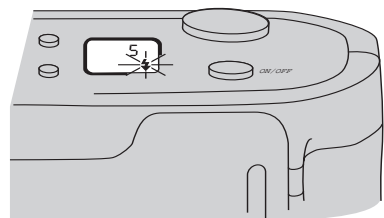

4. Press the shutter button **completely** down to take the picture.

Flash-to-Subject Distance

ISO Film Speed	Flash-to-Subject Distance
100	2.5 to 12 ft (0.8 to 3.7 m)
200	2.5 to 13 ft (0.8 to 4.0 m)
400	3.3 to 18 ft (1.0 to 5.6 m)
1000	5.2 to 29 ft (1.6 to 8.9 m)

Using the Red-Eye Reduction

Some people's eyes (and some pets') can reflect flash with a red glow. To minimize red eye in flash or fill-flash pictures, use the red-eye-reduction feature.

1. Press the On/Off Button (2) to turn the camera ON.
2. Press the Mode-Selection Button (4) once to move to the red-eye-reduction position. Make sure the Red-Eye-Reduction Indicator (32) appears on the LCD Panel (3).

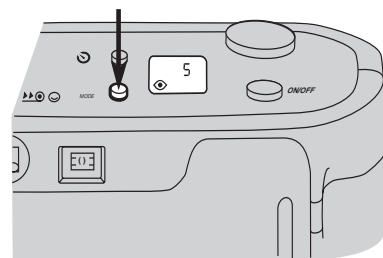

3. Press the Shutter Button (1) to take the picture.
4. To cancel the red-eye-reduction feature, turn the camera off or press the mode-selection button to return to the auto-flash/start position.

NOTE: When you take flash pictures using this feature, the camera fires a short flash before the picture is taken. The subject's eye pupil closes partially to reduce the red-eye effect.

Using the Fill Flash and Flash Off

Fill Flash — Bright light indoors or outdoors from backlit subjects can create dark shadows (especially on faces) in high-contrast scenes. Use fill flash to lighten these shadows.

Flash Off — When you do not want to use the flash, especially indoors where flash is prohibited, such as in theaters and museums, or in dim lighting situations, use flash off. Use a tripod (tripod socket [19]) or place the camera on another firm support.

1. Press the On/Off Button (2) to turn the camera ON.
2. Press the Mode-Selection Button (4) to select fill flash (29) or flash off (30). Make sure the correct indicator for the selected mode appears on the LCD Panel (3).

3. Press the Shutter Button (1) to take the picture.
- NOTE:** The camera automatically returns to the auto-flash/start position after you take the picture.

Flash Tips

- Turn on room lights and have the subject face the lights to minimize red eyes in pictures.
- Stand at an angle to shiny surfaces like windows or mirrors to avoid flash reflection and bright spots in your pictures.
- Keep your fingers and other objects away from the picture-taking lens, flash, and auto-focus windows to avoid dark or light pictures.

6 UNLOADING THE FILM

Within a few seconds after the last picture is taken, the film automatically starts to rewind. The Picture Counter (27) on the LCD Panel (3) blinks "0" when the film is finished rewinding. Wait for the camera motor to stop before you open the film door and remove the film. Reload the camera with fresh Kodak film.

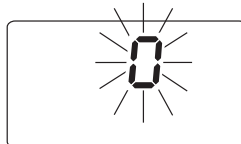

Using the Rewind Button

If you don't want to take pictures on the entire roll of film, you can automatically rewind the film by pressing the Rewind Button (5).

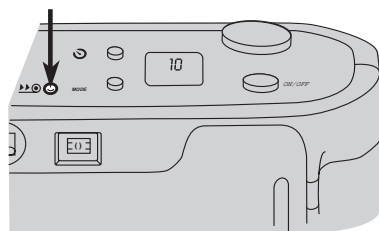

CARING FOR YOUR CAMERA

1. Protect the camera from dust, moisture, sudden impact, and excessive heat. **CAUTION:** Do not use solvents or harsh or abrasive cleaners on the camera body.
2. If the lens appears dirty, breathe on it to form a mist and wipe the surface gently with a soft, lintless cloth or lens-cleaning tissue. Do not apply pressure or you will scratch the lens. Never wipe a dry lens. **CAUTION:** Do not use solvents or solutions not designed for cleaning camera lenses. Do not use chemically treated tissues intended for cleaning eyeglasses.
3. Remove the battery when you store the camera for a long time. **CAUTION:** To prevent possible damage and electrical shock, do not try to take apart or repair the camera or flash unit by yourself.

TROUBLESHOOTING

What happened	Probable cause	Solution
Camera will not operate	Power off	Press on/off button
	Flash not ready	Wait for the flash-charging indicator on LCD panel to stop blinking
	Film not loaded	See LOADING THE FILM
	There are no more pictures remaining	Remove the film
Film does not advance	Battery weak, dead, missing, or improperly inserted	Replace or reload the battery; see LOADING THE BATTERY
	Film completely used (LCD panel has steady "0")	See LOADING THE FILM
	Film not loaded properly	See LOADING THE FILM
Film does not rewind	Film did not load properly	See LOADING THE FILM
	Battery weak, dead, missing, or improperly inserted	Replace or reload the battery; see LOADING THE BATTERY
LCD panel is blank	Battery weak, dead, missing, or improperly inserted	Replace or reload the battery; see LOADING THE BATTERY

FOR OWNERS OF THE QUARTZ DATE & TIME MODEL

SETTING THE DATE AND TIME

The date and time feature enables you to record the date in a choice of four formats: (month/day/year, day/month/year, year/month/day) or time (day/hour/minute) directly onto the film. It features a quartz clock and automatic calendar through the year 2019, including leap years. With the camera held horizontally, the data is recorded onto the lower right portion of the picture; in the vertical format with the shutter release up, imprinting occurs on the lower left portion but positioned horizontally on the picture.

Date and Time Imprinting

Press the Mode Button (b), located on the film door (20), to select the desired data type; then take the picture. Following the exposure, the Print Indicator (a) blinks in the data panel for approximately two-to-three seconds to confirm imprinting.

NOTE: The imprinted data may be difficult to read if the subject area over which it is superimposed is bright or non-uniform. If the data panel is consistently dim, replace the date-back battery (see **Replacing the Date-Back Battery** below).

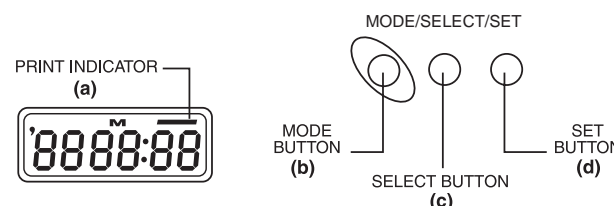

Mode Selection

Use the Mode Button (b) to change the data display as shown.

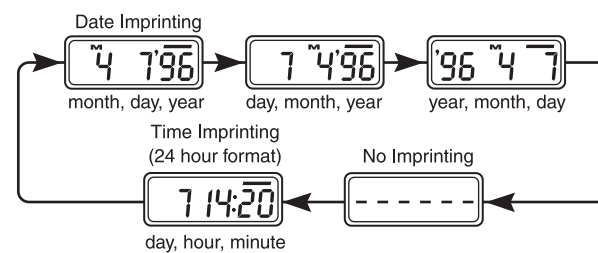

Setting Data

1. Press the Mode Button (b) to select the desired data type.
2. Use the Select Button (c) to move between different parts of the displayed data. With the data displayed, pressing the select button in succession causes the settings for year, month, and then day to blink. On the data panel, the letter "M" indicates the location for the month and the apostrophe " ' " for the year. In time mode, pressing the select button successively causes the hour, minute, and then the colon to blink.
3. Press the Set Button (d) to change the blinking display.

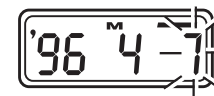

Replacing the Date-Back Battery

1. Open the Film Door (20).
2. Slide the Film-Pressure Plate (e) to the right until the silver spring clears the Retaining Ears (f) and reveals the Battery Cover (g).
3. Remove the screw from the battery cover using a small Phillips screwdriver.
4. Insert a new 3-volt lithium CR2025 (+ side up) battery. Replace the battery cover making sure the square Tab (h) is under the top retaining ear.
5. Reattach the screw and slide the film-pressure plate back, making sure it engages into the Center Notch (i) and is under both retaining ears on the film door.

NOTE: After you replace the battery, you will need to reset the date and time.

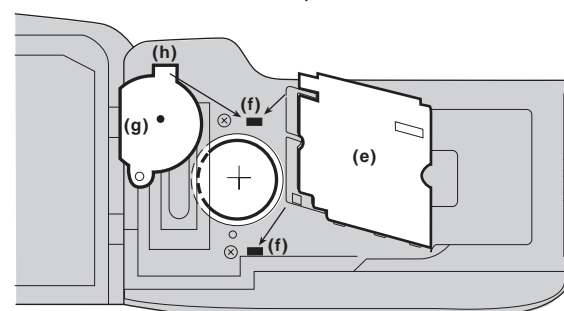
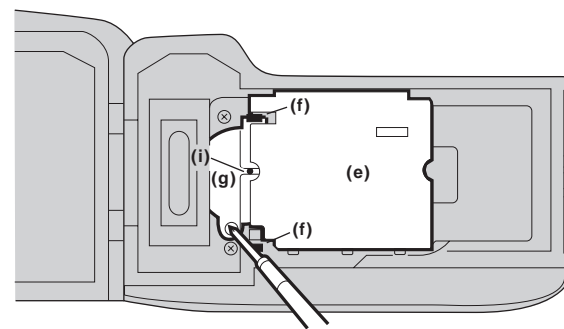

Date back subject to minor appearance and specification changes.

SERVICE INFORMATION

Where to Get Help

If you have any questions about your camera or difficulty in using it, reread the camera manual and check the **TROUBLESHOOTING** section.

If you purchased this camera in the United States and have difficulty that isn't covered in the TROUBLESHOOTING section of the camera manual, obtain help from one of these resources:

1. Take the camera, the film you were using, and any sample prints to your photo dealer.
2. Call Kodak toll free (in the United States) from 8:00 a.m. to 8:00 p.m. (Eastern Time Zone) Monday through Friday at 1 (800) 242-2424.

Packing Instructions

1. Include a note with your camera, giving all details: model, date of purchase, place of purchase, a description of the problem, sample negatives and prints, a **copy of the dated sales receipt**, and your name and address. If possible, include a telephone number where you can be reached between 8:00 a.m. and 5:00 p.m. (Eastern Time Zone).
2. Place the camera in a plastic bag to keep out dirt and packing material.
3. Use a sturdy carton that is large enough for you to surround the camera completely with packing material such as crumpled newspaper.
4. Securely fasten the carton with tape. Clearly write the address of the repair location and your name and address on the top and bottom of the carton. Be sure to verify a repair location before you ship the camera by calling Kodak toll free (in the United States) from 9:00 a.m. to 8:00 p.m. (Eastern Time Zone) Monday through Friday at 1 (800) 242-2424.
5. When you ship the carton, it is a good idea to insure the camera for replacement value.

WARRANTY INFORMATION

Full One-Year Warranty

THIS WARRANTY APPLIES ONLY TO CAMERAS PURCHASED IN THE UNITED STATES.

Warranty Time Period

This 35 mm KODAK Camera is warranted by Kodak to function properly for one year from the date of purchase. This warranty covers the purchaser of this camera and anyone else who owns it during the warranty period.

Warranty Coverage

If this camera does not function properly within the warranty period, **upon submission of a copy of a dated product sales receipt (keep the original for your records)**, Kodak will repair it without charge. If Kodak is unable to repair the camera, the option of replacement or refund of the purchase price will be offered.

How to Obtain Service

For assistance in using the camera, contact a dealer in Kodak products. For service on this camera, return it through a dealer in Kodak products, or call 1 (800) 242-2424 for the authorized warranty repair location nearest you. When sending a camera for service, enclose a note giving details of the problem and your complete name and address and phone number where you can be reached during the day to help the repair location return the camera promptly.

Limitations

This warranty does not apply to the battery used in this camera.

This warranty does not cover circumstances beyond Kodak's control, nor problems caused by failure to follow the care and operating instructions in the manual.

Warranty service will not be provided **without a copy of a dated product sales receipt (always keep the original for your records)**.

Kodak makes no other express warranty for this product.

Repair and the option of replacement or refund, in the event that Kodak is unable to repair the camera, are Kodak's only obligations. **Kodak will not be responsible for any consequential or incidental damages resulting from the sale or use of this camera, regardless of the cause of such damages.**

Your Rights under State Law

Some states do not allow the exclusion or limitation of incidental or consequential damages, so the above limitation or exclusion may not apply to you. This warranty gives you specific legal rights, and you may also have other rights which vary from state to state.

Outside the United States

In countries other than the United States, the terms of this warranty may be different. Unless a specific Kodak warranty is communicated to the purchaser in writing by a Kodak company, no warranty or liability exists beyond any minimum requirements imposed by law, even though defect, damage, or loss may be by negligence or other act.