

**FUJIFILM**

DIGITAL CAMERA

# *FinePix A203 / FinePix A303*

**Exif Print**  
xD  
xD-Picture Card

Designed for  
Microsoft®  
Windows® XP

**digital**  
Tools for the imagination.



Getting Ready **1**

Basic Photography **2**

Advanced Features  
Photography **3**

Advanced Features  
Playback **4**

Settings **5**

Software Installation **6**

Camera Connection **7**

Using FinePixViewer **8**

**OWNER'S MANUAL**

This manual will show you how to use your FUJIFILM DIGITAL CAMERA FinePix A203/FinePix A303 correctly. Please follow the instructions carefully.

BL00147-200 (1) **E**

# Warning

---

To prevent fire or shock hazard, do not expose the unit to rain or moisture.

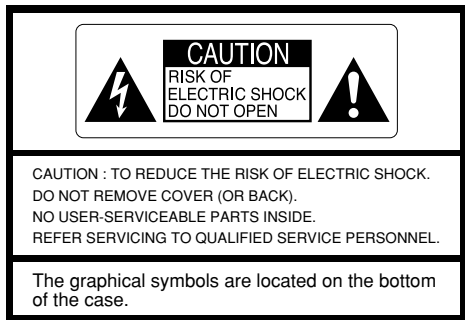

This symbol is intended to alert the user to the presence of uninsulated “dangerous voltage” within the product’s enclosure that may be of sufficient magnitude to constitute a risk of electric shock to persons.



This symbol is intended to alert the user to the presence of important operating and maintenance (servicing) instructions in the literature accompanying the appliance.

## For customers in the U.S.A.

### FCC Statement

This device complies with part 15 of the FCC Rules. Operation is subject to the following two conditions: (1) This device may not cause harmful interference, and (2) this device must accept any interference received, including interference that may cause undesired operation.

---

## CAUTION

This equipment has been tested and found to comply with the limits for a Class B digital device, pursuant to Part 15 of the FCC Rules. These limits are designed to provide reasonable protection against harmful interference in a residential installation. This equipment generates, uses, and can radiate radio frequency energy and, if not installed and used in accordance with the instructions, may cause harmful interference to radio communications. However, there is no guarantee that interference will not occur in a particular installation. If this equipment does cause harmful interference to radio or television reception, which can be determined by turning the equipment off and on, the user is encouraged to try to correct the interference by one or more of the following measures:

- Reorient or relocate the receiving antenna.
- Increase the separation between the equipment and receiver.
- Connect the equipment into an outlet on a circuit different from that to which the receiver is connected.

— Consult the dealer or an experienced radio/TV technician for help.

You are cautioned that any changes or modifications not expressly approved in this manual could void the user's authority to operate the equipment.

### Notes on the Grant:

To comply with Part 15 of the FCC rules, this product must be used with a Fujifilm-specified ferrite-core USB cable and DC supply cord.

## For customers in Canada

### CAUTION

This Class B digital apparatus complies with Canadian ICES-003.

**Please read the Safety Notes (→P.125)  
and make sure you understand them  
before using the camera.**

# Contents

Warning .....	2
Preface .....	6
Accessories .....	7
Nomenclature/Attaching the strap .....	8

## 1 Getting Ready

LOADING THE BATTERIES AND xD-Picture Card ..	11
SWITCHING ON AND OFF .....	14
SETTING THE DATE AND TIME .....	15
Changing the date and time .....	16
To change the date display format .....	16
SELECTING THE LANGUAGE .....	18

## 2 Basic Photography

BASIC OPERATION GUIDE (PHOTOGRAPHY) .....	19
BASIC OPERATION GUIDE (PLAYBACK) .....	20
BASIC OPERATION GUIDE (MENU) .....	21

### STILL IMAGE

TAKING PICTURES (  AUTO MODE) .....	22
■ Viewfinder Lamp Display .....	27
Number of Available Frames .....	28
USING AF/AE LOCK .....	30
FRAMING GUIDELINE FUNCTION .....	32
USING THE ZOOM .....	33
⚡ FLASH .....	34
Auto Flash Mode (Blank) .....	34
👁 Red-Eye Reduction .....	35

⚡ Forced Flash .....	35
🔇 Suppressed Flash .....	36
⚡ Slow Synchro .....	36



### PLAYBACK MODE

VIEWING YOUR IMAGES (PLAYBACK) .....	37
MULTI-FRAME PLAYBACK .....	38
PLAYBACK ZOOM .....	39
ERASING SINGLE FRAME .....	40

## 3 Advanced Features Photography

🌸 MACRO (CLOSE-UP) PHOTOGRAPHY .....	42
🕒 SELF-TIMER PHOTOGRAPHY .....	43

### MOVIE PHOTOGRAPHY

🎥 MOVIE (VIDEO) .....	45
BASIC PHOTOGRAPHY MENU OPERATIONS .....	48
SELECTING  AUTO OR  MANUAL .....	49
PHOTOGRAPHY MENU OPTIONS .....	50

### PHOTOGRAPHY MENU

🔍 SETTING THE QUALITY .....	52
📷 EV (EXPOSURE COMPENSATION) .....	54
🌓 WHITE BALANCE (SELECTING THE LIGHT SOURCE) .....	55

## 4 Advanced Features Playback

### PLAYBACK MODE

PLAYING BACK MOVIES (VIDEO) .....	56
■ Playing back movies .....	57

## PLAYBACK MENU

ERASING SINGLE •	
ALL FRAMES/FORMATTING .....	58
PROTECTING IMAGES FRAME/ALL .....	62
HOW TO SPECIFY PRINT OPTIONS (DPOF) ..	66
DPOF SET FRAME .....	67

## 5 Settings

ADJUSTING THE MONITOR BRIGHTNESS .....	71
USING SET-UP .....	72
■ SET-UP Menu Options (Date/time setting, etc.) .....	73

## SET-UP

POWER SAVE .....	74
------------------	----

## 6 Software Installation

6.1 The Software Components .....	75
6.2 Installation on a Windows PC .....	76
6.2.1 Load the CD-ROM into your PC .....	76
6.2.2 From FinePixViewer installation to restart ..	77
6.3 Installation on a Mac OS 8.6 to 9.2 .....	81
6.3.1 Check the system software settings .....	81
6.3.2 From FinePixViewer installation to restart ..	81
6.4 Installation on a Mac OS X .....	84
6.4.1 From FinePixViewer installation to restart ..	84

## 7 Camera Connection

7.1 Using the optional AC Power adapter .....	87
---	----

7.2 Use at DSC mode .....	88
7.3 Use at PC-CAM mode .....	91
7.4 Disconnecting the Camera .....	94

## 8 Using FinePixViewer

8.1 Saving Images on Your Computer and viewing images ..	96
8.2 Making a FinePix CD Album .....	97
8.3 Using the FinePix Internet Service .....	98
8.3.1 Using FAQ .....	98
8.3.2 User Registration .....	98
8.4 Mastering FinePixViewer .....	102
8.5 Uninstalling the Software .....	103

System Expansion Options .....	105
Accessories Guide .....	106
Notes on Using Your Camera Correctly .....	108
Notes on the Power Supply .....	109
Applicable Batteries .....	109
Notes on the Batteries .....	109
AC Power Adapter .....	111
Notes on the xD-Picture Card .....	112
Warning Displays .....	114
Troubleshooting .....	117
Specifications .....	120
Explanation of Terms .....	124
Safety Notes .....	125
EC Declaration of Conformity .....	129

1

2

3

4

5

6

7

8

# Preface

---

## ■ Test Shots Prior to Photography

For particularly important photographs (such as weddings and overseas trips), always take a test photograph and view the image to make sure that the camera is functioning normally.

- Fuji Photo Film Co., Ltd. cannot accept liability for any incidental losses (such as the cost of photography or the loss of income from photography) incurred as a result of faults with this product.

## ■ Notes on Copyright

Images recorded using your digital camera system cannot be used in ways that infringe copyright laws without the consent of the owner, unless intended only for personal use. Note that some restrictions apply to the photographing of stage performances, entertainments and exhibits, even when intended purely for personal use. Users are also asked to note that the transfer of memory cards containing images or data protected under copyright laws is only permissible within the restrictions imposed by those copyright laws.

## ■ Liquid Crystal

If the LCD monitor is damaged, take particular care with the liquid crystal in the monitor. If any of the following situations arise, take the urgent action indicated.

- If liquid crystal comes in contact with your skin  
Wipe the area with a cloth and then wash thoroughly with running water and soap.
- If liquid crystal gets into your eye  
Flush the affected eye with clean water for at least 15 minutes and then seek medical assistance.
- If liquid crystal is swallowed  
Flush your mouth thoroughly with water. Drink large quantities of water and induce vomiting. Then seek medical assistance.

## ■ Notes on Electrical Interference

If the camera is to be used in hospitals or aircrafts, please note that this camera may cause interference to other equipment in the hospital or aircraft. For details, please check with the applicable regulations.

## ■ Handling Your Digital Camera

This camera contains precision electronic components. To ensure that images are recorded correctly, do not subject the camera to impact or shock while an image is being recorded.

## ■ Trademark Information

- IBM PC/AT is a registered trademark of International Business Machines Corp. of the U.S.
- iMac and Macintosh are registered trademarks of Apple Computer, Inc.
- QuickTime and the QuickTime logo are trademarks used under license. The QuickTime logo is registered in the U.S. and other countries.
- Adobe Acrobat® Reader™ is a trademark of Adobe Systems Incorporated of the U.S.
- Microsoft, Windows, the Windows logo and DirectX are either trademarks, or registered trademarks of Microsoft Corporation in the United States and/or other countries. Windows is an abbreviated term referring to the Microsoft Windows Operating System.
- \* The “Designed for Microsoft Windows XP” logo refers to the camera and the driver only.
- xD-Picture Card and other company or product names are trademarks or registered trademarks of the respective companies.

## ■ Exif Print (Exif ver. 2.2)

Exif Print Format is a newly revised digital camera file format that contains a variety of shooting information for optimal printing.

# Accessories

---

- **16 MB, xD-Picture Card (1)**

Supplied with:

- Anti-static case (1)

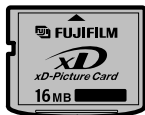

- **Interface Set (1)**

- CD-ROM: Software for FinePix SX (1)
- Special USB cable with Noise Suppression core (1)

- **Owner's Manual (this manual) (1)**

- **LR6 AA-size alkaline Batteries (2)**

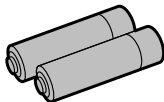

- **Hand strap (1)**



# Nomenclature

\* Refer to the pages in parentheses for information on using the camera features.

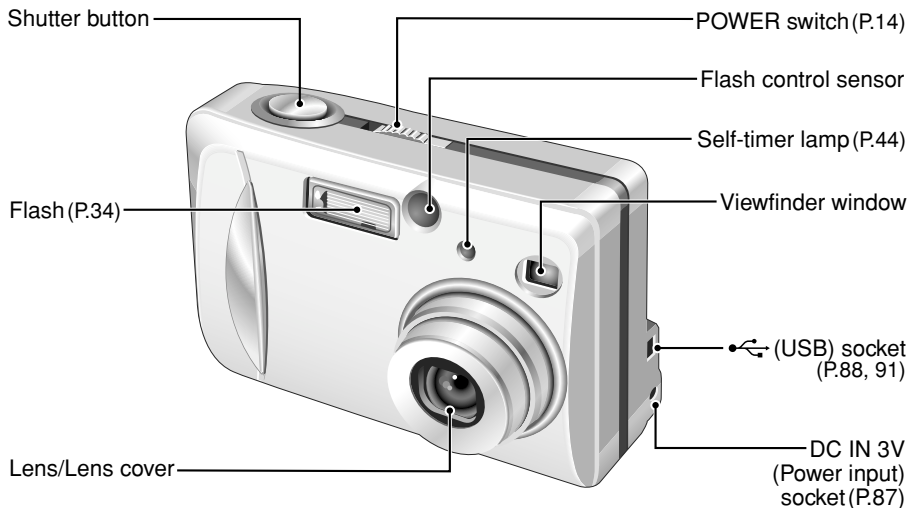

MENU/OK button (P.21)

BACK button (P.21)

Viewfinder

Viewfinder lamp

DISP button (P.19,20)

LCD monitor

⚡ Flash button

Tripod mount

Battery cover

xD-Picture Card slot

Battery compartment

**[ Mode dial ]**

Self-Timer mode (P.43)

Macro (close-up) mode (P.42)

Still photography mode (P.22)

Playback mode (P.37)

Movie mode (P.45)

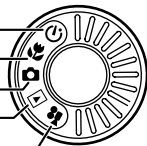

◀▶ button (P.20,21)

▲ ( [ ] Zoom in)

▼ ( [ ] Zoom out) button  
(P.19, 20, 21, 24, 33)

Strap mount (P.9)

**[ Attaching the strap ]**

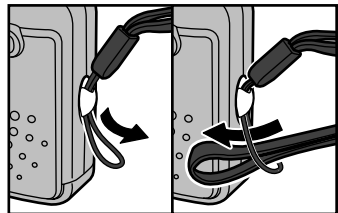

# Nomenclature (Sample display)

## Example of LCD Monitor Text Display: Still image

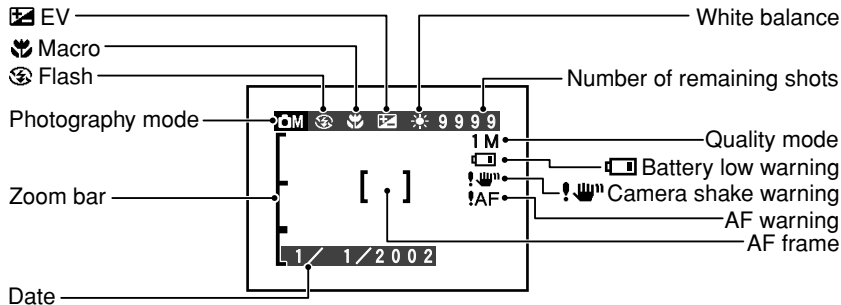

## Example of LCD Monitor Text Display: Playback

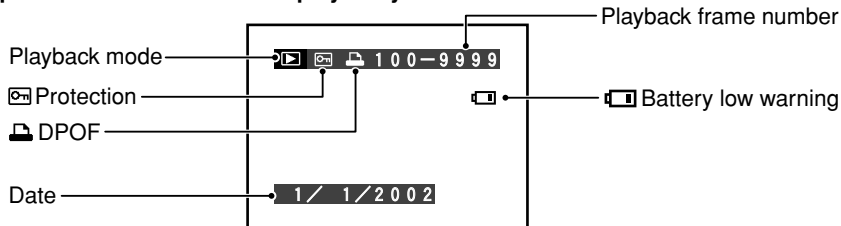

### Compatible batteries

Use two AA-size alkaline batteries or two AA-size nickel-metal hydride (Ni-MH) batteries.

#### ◆ Notes on Handling Batteries ◆

- It is recommended that you use the same brand of alkaline batteries as those supplied with the camera.
- Never use a battery when the outer casing is split or peeling as this could result in a short-circuit and cause major problems due to battery fluid leakage or overheating.
- You cannot use lithium, manganese or nickel-cadmium (Ni-Cd) batteries.
- Do not use different types of batteries or old and new batteries together.
- The operating lives of alkaline batteries vary between brands and the life of batteries you purchase may be shorter than the alkaline batteries provided with the camera. Note also that due to the nature of alkaline batteries, the time for which they can be used is shorter in cold locations (at temperatures of +10°C (+50°F) or below). Consequently, Ni-MH batteries are recommended.
- Soil (fingerprints, etc) on the terminals of batteries can greatly reduce the time for which the batteries provide power.
- You will need the optional charger (➔P.106) to recharge Ni-MH batteries.
- See P.109 for notes on using batteries.

#### Outer casing

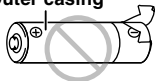

### xD-Picture Card (sold separately)

DPC-16 (16MB)

DPC-32 (32MB)

DPC-64 (64MB)

DPC-128 (128MB)

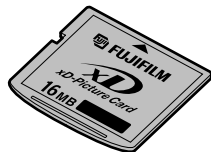

Front

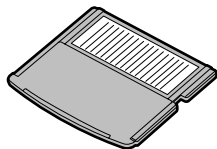

Back

- ⚠ Operation of this camera is only guaranteed when it is used with FUJIFILM xD-Picture Card.
- ⚠ See P.112-113 for more information on xD-Picture Card.

## LOADING THE BATTERIES AND xD-Picture Card

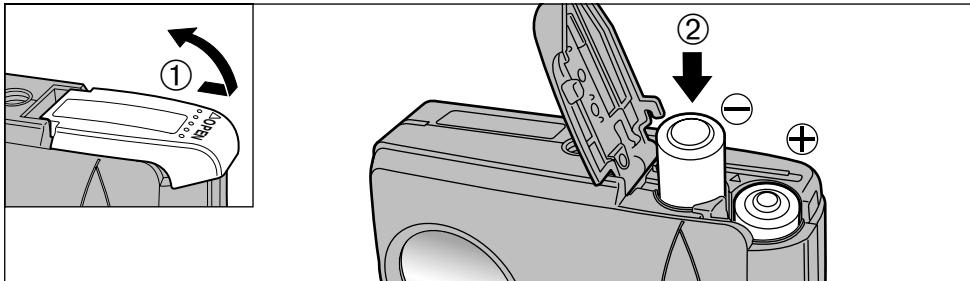

- ① Slide the battery cover out to open it.
- ② Load the batteries correctly as shown.

⚠ Do not apply excessive force to the battery cover.

Do not open the battery cover while the camera is still switched on. This could damage the xD-Picture Card or corrupt the image files on the xD-Picture Card.

### ◆ When you want to replace the battery ◆

Check that the camera is switched off, open the battery cover and then remove the batteries.

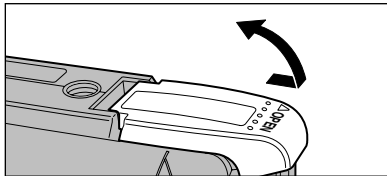

⚠ Take care not to drop the battery when opening and closing the battery cover.

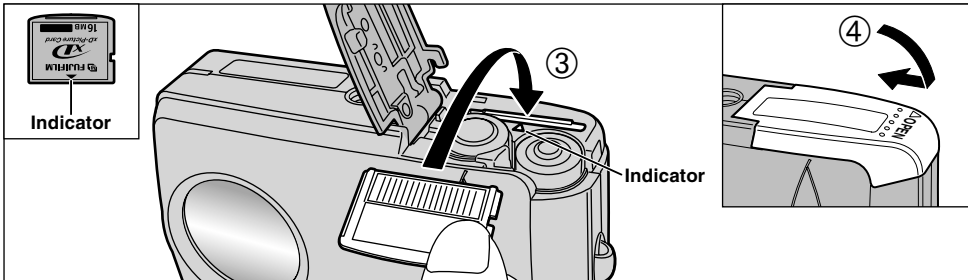

- ③ Align the arrows on the camera and the xD-Picture Card, and firmly push the card fully into the xD-Picture Card slot.
- ④ Close the battery cover.

- ⚠ If you open the battery cover while the camera is switched on, the camera automatically switches off to protect the data on the xD-Picture Card .
- ⚠ The xD-Picture Card will not slide fully into the slot if it is inserted facing the wrong way. Be careful not to apply undue force to the xD-Picture Card .
- ⚠ To protect the xD-Picture Card , always store it in the special anti-static case.

#### ◆ When you want to replace the xD-Picture Card ◆

When you push the xD-Picture Card into the slot and then slowly remove your finger, the lock is released and the xD-Picture Card is pushed out. You can then pull the xD-Picture Card the rest of the way out.

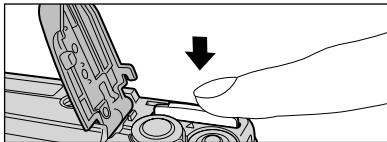

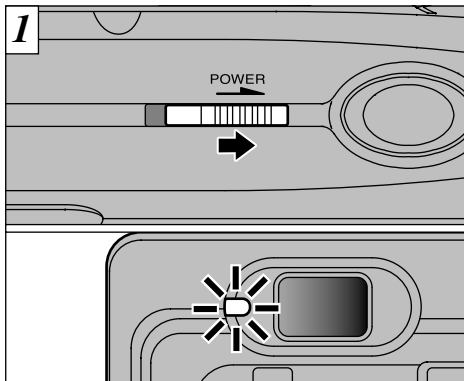

- ⚠ Take care not to remove your finger too quickly after the lock is released, as the card may spring completely out of the slot.

# SWITCHING ON AND OFF



Slide the “POWER” switch sideways to turn the camera on and off. When you switch the camera on, the viewfinder lamp lights (green).

In “” mode, the lens cover opens and the lens extends. Take care not to press on these precision components as this could result in a fault or a “ LENS COVER” message being displayed on the LCD monitor. Take care also not to leave fingerprints on the lens as this will degrade the picture quality.



When you first switch the camera on, the date is cleared. Press the “MENU/OK” button to set the date and time.

- ! To set the date and time later, press the “BACK” button.
- ! If you do not set the date and time, this confirmation screen will appear each time you switch the camera on.

# SETTING THE DATE AND TIME

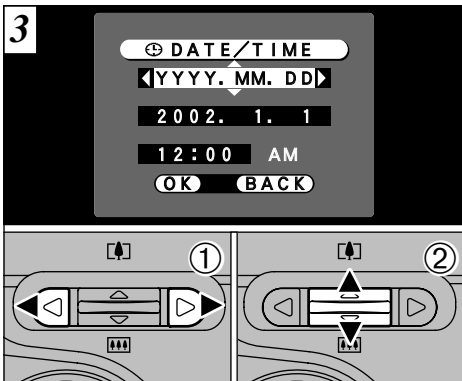

- ① Use “◀” or “▶” to select Year, Month, Day, Hour or Minute.
- ② Press “▲” or “▼” to set the number.

- ⚠ If you hold down “▲” or “▼”, the numbers change continuously.
- ⚠ When the time displayed passes “12:00”, the AM/PM setting automatically switches.



Once you have set the date and time, press the “MENU/OK” button. Pressing the “MENU/OK” button switches the camera to Photography or Playback mode.

- ⚠ To set the time more precisely, press the “MENU/OK” button when the time on your reference clock reaches zero seconds.
- ⚠ At the time of purchase and after you leave the camera for a long period with the batteries removed, settings such as the date and time are cleared.  
Unless the battery has been left in the camera for at least 20 minutes, the camera settings may not be retained when you replace the xD-Picture Card or battery.

## SETTING THE DATE AND TIME

### Changing the date and time

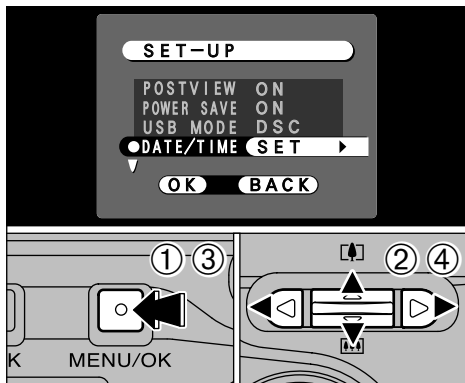

#### To change the date and time:

- ① Press the "MENU/OK" button.
- ② Use "◀" or "▶" to select "SET" OPTION and then use "▲" or "▼" to select "SET-UP".
- ③ Press the "MENU/OK" button.
- ④ Select "DATE/TIME" and press "▶".

See P.14, 15 for information on setting the date and time.

### To change the date display format

You can select your preferred date format.

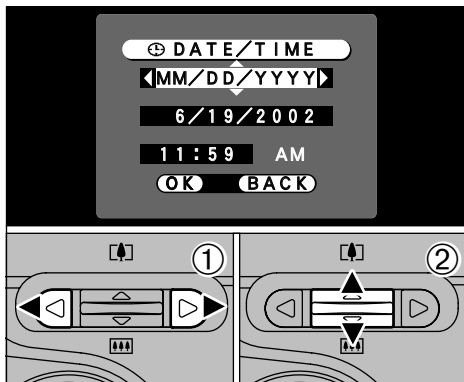

- ① Press "◀" or "▶" to select the date format.
- ② Press "▲" or "▼" to set the format. Refer to the table below for details of the settings.

Setting	Explanation
YYYY.MM.DD	Displays the date in the “year.month.day” format.
MM/DD/YYYY	Displays the date in the “month/day/year” format.
DD.MM.YYYY	Displays the date in the “day.month.year” format.

### ◆ Checking the remaining battery charge ◆

Switch the camera on and check that no battery level warning (🔋 or 🔋) is displayed on the LCD monitor. If no icon is displayed, there is ample charge left in the battery.

- 🔋 **Lit red:**  
The battery is low on charge. Have a new battery ready.
- 🔋 **Blinking red:**  
The battery is exhausted. The display will shortly go blank and the camera will stop working. Replace or recharge the battery.

! The above estimates are for the Still photography modes. In Playback mode, the transition from “🔋” to “🔋” may take less time.

### ◆ Power Save Function ◆

If the camera is not used for 2 minutes, this function automatically switches the camera off. When this function is active, it also switches off the LCD monitor to reduce power consumption if the camera is not used for 30 seconds (See P.74 for details).

# SELECTING THE LANGUAGE

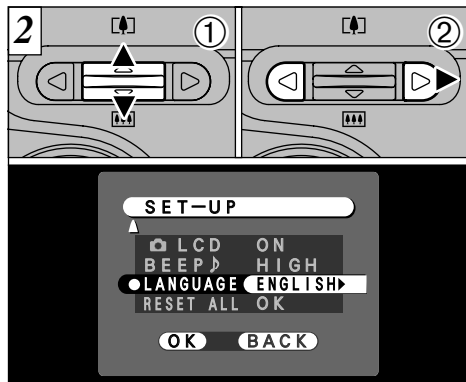
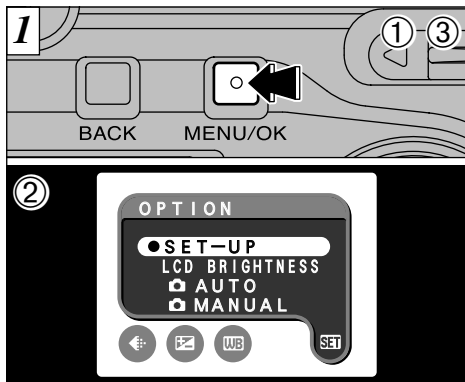

- ① Press the “MENU/OK” button to display the menu screen.
- ② Use “▲▼◀▶” to select “SET-UP” from the “SET” OPTION menu.
- ③ Press the “MENU/OK” button.

- ① The “SET-UP” screen appears. Use “▲” or “▼” to select “LANGUAGE”.
- ② Use “▶” to select “ENGLISH”, “FRANCAIS” or “DEUTSCH”. You can cycle through the language settings by pressing “▶”.

- ! The screens in this manual are shown in English.
- ! See P.72, 73 for more information on the “SET” OPTION menu.

## ● Switching the LCD monitor on and off

Select one of the following modes:

### LCD monitor ON

Normally, set the LCD monitor to ON.

### LCD monitor OFF

Switch the LCD monitor OFF to reduce power consumption.

### Framing Guidelines

Display these as a guide to composing your shots.

\* You can further reduce power consumption by switching preview image checking OFF.

## ● Power switch

Slide this switch sideways to turn the camera on and off.

## ● Focus and shoot

**Pressed halfway** : Sets the focus.

**Pressed fully** : Releases the shutter.

## ● Zoom

▲ ( [ ] ) : Zooms in.

▼ ( [ ] ) : Zooms out.

## ● Mode dial

Select one of the following 4 photography modes:

- : Still photography
- : Macro (close-up)
- : Self-timer
- : Movie

\* Setting the mode dial to " [ ] " switches the camera to Playback mode.

## ● Flash button

Select one of the following 5 flash modes:

AUTO, , , ,

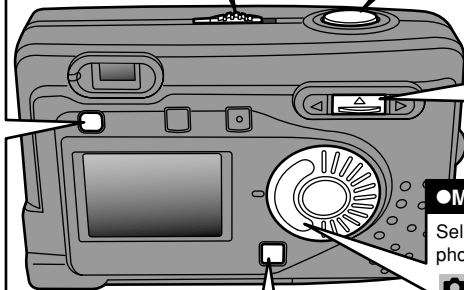

# BASIC OPERATION GUIDE (PLAYBACK)

## ●DISP button

Select one of the following 3 modes:

### **Text displayed :**

Normally, use this setting.

### **Text not displayed :**

No text is displayed.

### **Multi-frame playback :**

Displays 9 image frames.

## ●Power ON/OFF

Slide this switch sideways to turn the camera on and off.

## ●Playback frame selector

▶ : Selects the next frame.

◀ : Selects the previous frame.

## ◆ Displaying help ◆

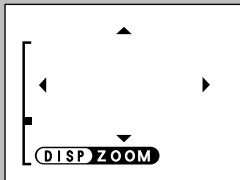

This feature displays help on moving to the next step at the bottom of the screen. Press the corresponding button.

## ●Mode dial

Set the mode dial to "▶".

## ●Playback zoom

▲ ( [ ] ) :  
Increases the display scale (zooms in).

▼ ( [ ] ) :  
Decreases the display scale (zooms out).

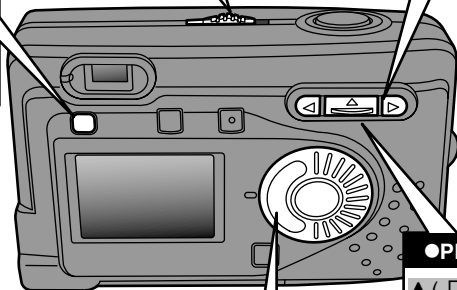

# BASIC OPERATION GUIDE (MENU)

## ●To cancel a procedure mid-way

Press the "BACK" button.

Up, down, left and right are indicated by black triangles in the Owner's Manual. Up or down is shown as "▲▼", and left or right is shown as "◀▶".

## ●Using the Menu

① Display the menu.

Press the "MENU/OK" button.

② Select a menu option.

Press "◀" or "▶".

③ Select a setting.

Press "▲" or "▼".

④ Confirm the setting.

Press the "MENU/OK" button.

You have read the section called “Getting Ready” and now your camera is ready to take pictures.

The “Basic Photography” section takes you through the basic procedures of “Shooting”, “Viewing” and “Erasing” pictures.

Master these basic operations by trying them out as you read through the manual.

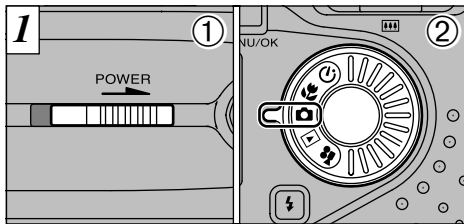
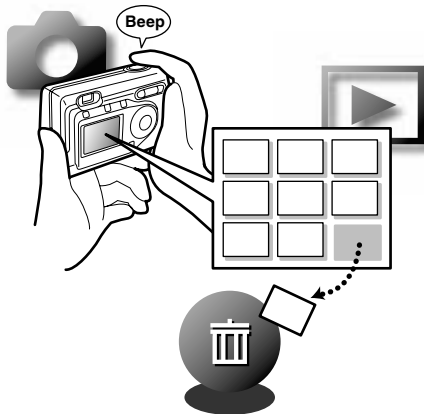

① Slide the “POWER” switch sideways to switch the camera on.

② Set the Mode dial to “📷”.

● **Photography range:** Approx. 60 cm (2 ft.) to infinity

! For subjects closer than 60 cm (2 ft.), use Macro photography (➡P.42).

### ◆ To increase your shooting time ◆

- Press the “DISP” button to switch the LCD monitor off and use the viewfinder to take pictures (Note that you cannot switch the LCD monitor off in Macro mode).
- Set “POSTVIEW” in the “SET-UP” menu to “OFF” (➡P.73).
- Set “POWER SAVE” in the “SET-UP” menu to “ON” (➡P.73, 74).

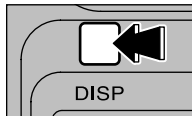



Brace your elbows against your sides and hold the camera with both hands.  
Hold the camera so that your right thumb is conveniently positioned for operating the zoom.

- ❗ If the “**! CARD ERROR**”, “**! WRITE ERROR**”, “**! READ ERROR**” or “**! CARD NOT INITIALIZED**” message appears, see P.114 and P.115.
- ❗ If you use the flash in very dusty environments or when it is snowing, the flash may reflect off the dust particles or snowflakes and appear as white dots in your images.

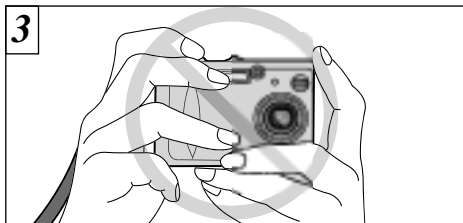

Be careful to ensure that the lens, flash and flash control sensor are not obscured by your hands or the camera strap.  
The camera may not be able to take successful pictures if your fingers or the strap are in the way.

- ❗ Check that the lens is clean. If it is dirty, clean the lens as described on P.108.

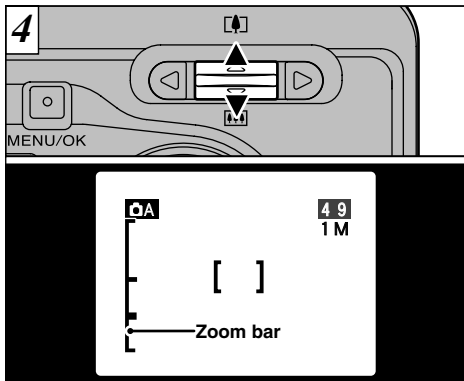

To zoom in on the subject, press “▲” (TELE). To zoom out, press “▼” (WIDE). A “zoom bar” appears on the LCD monitor when you zoom in or out.

● **Optical zoom focal length (35mm camera equivalent)**

Approx. 38 mm-114 mm Maximum zoom scale: 3×

! Zooming stops briefly when the camera switches between optical zoom and digital zoom (⇒P.33).

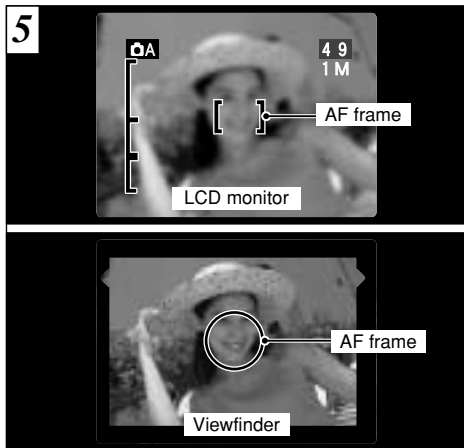

Using the viewfinder or LCD monitor, frame your shot so that the subject fills the entire AF (Auto Focus) frame.

! If your subject is not in the center of the picture, use AF/AE lock to take the picture (⇒P.30).

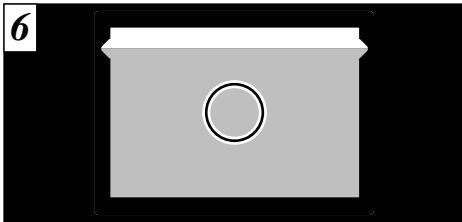

When you are using the viewfinder to take a picture at a distance of 80 cm to 1.5 m (2.6 ft. to 4.9 ft.), only the shaded area in the figure is photographed.

- ❗ To frame your shot precisely, you should take the picture using the LCD monitor.
- ❗ In some conditions it may be difficult to see your subject clearly on the LCD monitor (such as in sunny weather outdoors or when you are shooting dimly lit scenes). In such situations, use the viewfinder to take the shot.
- ❗ The image shown on the LCD monitor before you take the shot may differ in its brightness, color, etc. from the image actually recorded. If necessary, play back the recorded image to check it (➡P.37).

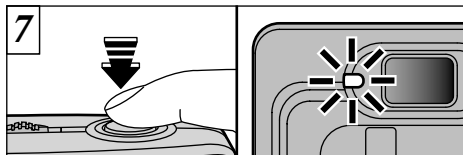

Press the shutter button down halfway. Focusing is complete when the AF frame on the LCD monitor shrinks and the viewfinder lamp (green) stops flashing and remains lit.

- ❗ If “!AF” appears on the screen, the camera cannot focus.
- ❗ When you press the shutter button down halfway, the image on the screen freezes temporarily. However, this image is not the recorded image.
- ❗ If “!AF” is displayed on the screen (e.g. the shot is too dark for the camera to focus), try standing about 2 m (6.6 ft.) from your subject to take the picture.

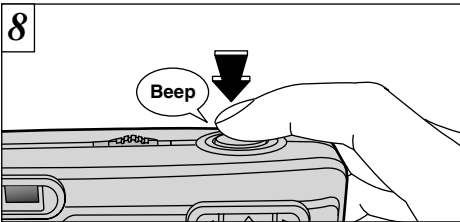

To take the picture, press the shutter button down fully without lifting your finger off it. The camera beeps and takes the picture, and the data is then recorded.

- ❗ If you press the shutter button down fully in one motion, the shot is taken without the AF frame changing.
- ❗ When you take a picture, the viewfinder lamp lights orange (camera not ready) before switching back to green to indicate that the camera is again ready for shooting.
- ❗ The viewfinder lamp flashes orange while the flash is charging. If the LCD monitor is switched on, the screen may go dark for a moment. This is normal and does not indicate a fault.
- ❗ See P.114-116 for information on the warning displays.

### ◆ Warnings Displayed When the Shutter is Pressed Halfway ◆

**!AF** The camera cannot focus.

#### Solution

- Ensure that you are at least 2 m (6.6 ft.) from the subject when you take the shot.
- Use AF/AE lock to take the shot (→P.30).



There is a high risk of camera shake due to the slow shutter speed.

#### Solution

- Use the flash.
- Use a tripod.

**!AE** You can take the shot, but it will not be correctly exposed.

**■ Viewfinder Lamp Display** \* When the LCD monitor is switched on, more detailed warning messages are displayed (➡P.114-116).

Display	Status
Lit green	Ready to shoot.
Blinking green	AF/AE in progress, camera shake warning or AF warning (Ready to shoot).
Blinking green and orange alternately	Recording to xD-Picture Card (Ready to shoot).
Lit orange	Recording to xD-Picture Card (Not ready).
Blinking orange	Flash charging (Flash will not fire).
Blinking red	<ul style="list-style-type: none"> <li>● xD-Picture Card Warnings No card loaded, card not formatted, incorrect format, card full, xD-Picture Card error.</li> <li>● Lens operation error.</li> </ul>

**◆ Subjects Not Suitable for Autofocus ◆**

Though the FinePix A203/FinePix A303 uses an accurate autofocus mechanism, it may have difficulty focusing or not be able to focus at all for the types of subject and situation listed below. In such cases, the image may be out of focus.

- Very shiny subjects such as a mirror or car body.
- Subjects photographed through glass.
- Subjects that do not reflect well, such as hair or fur.
- Subjects with no substance, such as smoke or flames.
- When the subject is dark.
- When there is very little contrast between the subject and the background (such as white walls or subjects dressed in the same color as the background).
- Subjects moving at high speed.
- When something other than your subject is close to the AF frame, has contrasting areas of light and dark and is either closer or further away than your subject (as when you photograph someone against a background with strongly contrasting elements).

For subjects of this type, use AF/AE lock (➡P.30).

## Number of Available Frames



The number of available shots is displayed on the LCD monitor.

## Standard number of shots per xD-Picture Card

The number of available shots when the xD-Picture Card is formatted in the camera.

- ! Because the amount of data recorded varies depending on the subject, the number of available shots may not decrease when recording ends, or in some cases may decrease by 2 frames.
- ! Also, the discrepancy between the actual number of available shots and the standard number of shots tends to be larger when the capacity of the xD-Picture Card is larger.

- ! See P.52 for information on changing the Quality (number of recorded pixels).

### ■ FinePix A203

Quality Mode	2M • F	2M • N	1M	0.3M
Number of recorded pixels	1600 × 1200		1280 × 960	640 × 480
Image Data Size	Approx. 620 KB	Approx. 390 KB	Approx. 320 KB	Approx. 130 KB
DPC-16 (16 MB)	25	39	49	122
DPC-32 (32 MB)	50	79	99	247
DPC-64 (64 MB)	101	159	198	497
DPC-128 (128 MB)	204	319	398	997

### ■ FinePix A303

Quality Mode	3M • F	3M • N	2M	1M	0.3M
Number of recorded pixels	2048 × 1536		1600 × 1200	1280 × 960	640 × 480
Image Data Size	Approx. 1300 KB	Approx. 590 KB	Approx. 390 KB	Approx. 320 KB	Approx. 130 KB
DPC-16 (16 MB)	12	26	39	49	122
DPC-32 (32 MB)	25	53	79	99	247
DPC-64 (64 MB)	50	107	159	198	497
DPC-128 (128 MB)	102	215	319	398	997

# USING AF/AE LOCK



In a shot with this type of composition, the subjects (two people in this case) are not in the AF frame. If the shot is taken at this point, the subjects will not be in focus.



Move the camera slightly so that one of the subjects in the AF frame.

## ◆ AF (Autofocus)/AE Lock (Auto-exposure) ◆

On the FinePix A203/FinePix A303, when you press the shutter button down half way, the focus and exposure settings are fixed (AF/AE lock). If you want to focus on a subject that is off to one side of the image or if you want to set the exposure before you compose the final shot, lock the AF and AE settings and then compose and shoot your picture to get the best results.

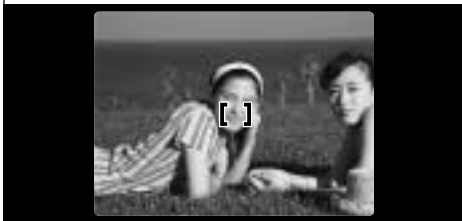
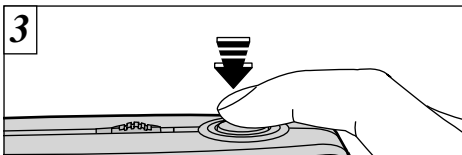

Hold the shutter button down halfway (AF/AE Lock) and check that the AF frame on the LCD monitor shrinks.

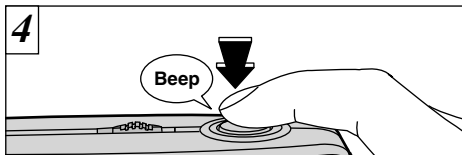

Continue to hold the shutter button down halfway (AF/AE lock). Move the camera back to the original image and then fully press down on the shutter button.

- ⚠ You can reapply the AF/AE lock as many times as you like before releasing the shutter.
- ⚠ The AF/AE lock operates in all photography modes and can be used to ensure excellent results.

# FRAMING GUIDELINE FUNCTION

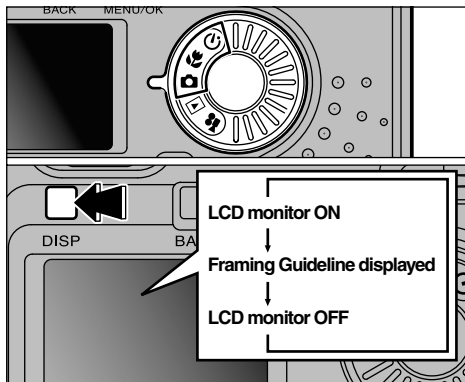

This function can be specified in the “📷”, “🌸” and “🕒” modes. The mode shown on the LCD monitor switches each time you press the “DISP” button. Press the “DISP” button to display the framing guideline.

- ❗ The framing guideline is not recorded on the image.
- ❗ The lines in the scene frame roughly divide the recorded pixels into three equal parts horizontally and vertically. When the image is printed, the resulting print may be shifted slightly from the scene frame.

## Scene

Use this frame when you want to position your main subject in the center of the frame or when you want to align your shot with the horizon. This feature provides a clear guide to the subject size and the overall balance of the shot so that you get exactly the shot you want.



## ◆ Important ◆

Always use the AF/AE lock to compose your picture.  
Failing to use the AF/AE lock may result in the image being out of focus.

# USING THE ZOOM

Press “▲” to zoom in and make your subject larger. Press “▼” when you want to zoom out and shoot a wider area. If you use the LCD monitor to take pictures, you can continue zooming with the digital zoom after the optical zoom finishes.

## ■ FinePix A203

	Digital zoom focal distance (35 mm camera equivalent)	Maximum zoom scale
2M	Cannot be used	
1M	Equivalent to approx. 114 mm-146 mm	1.3×
0.3M	Equivalent to approx. 114 mm-285 mm	2.5×

## ■ FinePix A303

	Digital zoom focal distance (35 mm camera equivalent)	Maximum zoom scale
3M	Cannot be used	
2M	Equivalent to approx. 114 mm-146 mm	1.3×
1M	Equivalent to approx. 114 mm-182 mm	1.6×
0.3M	Equivalent to approx. 114 mm-365 mm	3.2×

! See P.52 for information on changing the quality setting.

### Zoom bar display **FinePix A303 only**

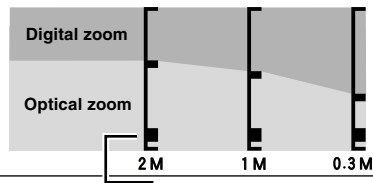

The position of the “■” on the zoom bar indicates the current zoom setting.

- If the “■” is above the dividing line, the digital zoom is being used. If it is below the line, the optical zoom is being used.
- Press “▲” or “▼” to move the “■” up or down.
- When you switch between digital zoom and optical zoom, the “■” stops moving briefly. Press the button for the same direction again to start the “■” moving and switch the zoom setting.
- ! If the image goes out of focus when you use the zoom, press the shutter button down halfway to refocus.
- ! The optical zoom is equivalent to approximately 38 mm-114 mm on a 35 mm camera.

2

## ⚡ FLASH

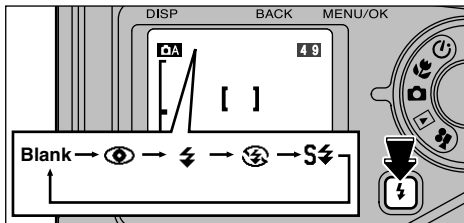

Press the “⚡” button to select the flash setting. Use the flash mode that best suits your shot.

- **5 flash modes:** “AUTO” (no icon), “👁️”, “⚡”, “⚡/”, and “⚡/”.
- **Effective flash range (📷 in AUTO mode):**
  - Wide-angle: Approx. 30 cm to 3.5 m (1.0 ft.-11.5 ft.)
  - Telephoto: Approx. 60 cm to 3 m (2.0 ft.-9.8 ft.)
- ⚠️ If you use the flash in very dusty environments or when it is snowing, the flash may reflect off the dust particles or snowflakes and appear as white dots in your images.
- ⚠️ The flash charging time may increase if the charge remaining in the batteries is low.
- ⚠️ When you take a shot using the flash, you may see the video image disappear and the screen go dark as the flash charges. The viewfinder lamp flashes orange while the flash is charging.



### Auto Flash Mode (Blank)

Use this mode for ordinary photography. The flash fires automatically as required by the shooting conditions.



### **Red-Eye Reduction**

Use this mode to ensure that the subject's eyes appear natural when photographing people in low-light conditions. The flash fires automatically as required by the photography conditions. The flash fires a pre-flash just before the picture is taken and then fires again to take the actual picture.



### **Forced Flash**

Use this mode to photograph backlit scenes, such as a subject against a window or in the shade of a tree, or to obtain the correct colors when you are shooting under lighting such as fluorescent tubes. In this mode, the flash fires in bright as well as dark conditions.

### ◆ **Red-Eye Effect** ◆

When you use the flash to photograph people in low-light conditions, their eyes sometimes appear red in the picture. This is caused by the light of the flash reflecting off the inside of the eye. Use Red-Eye Reduction flash to effectively minimize the likelihood of the red-eye effect.

Take the following measures also to make Red-Eye Reduction more effective:

- Get the subjects to look at the camera.
- Get as close as possible to the subjects.

## ⚡ FLASH



### Ⓜ Suppressed Flash

Use this mode for photography using indoor lighting, for shots taken through glass, and for photography in venues such as theaters or at indoor sporting events where the distance is too great for the flash to be effective. When you use Suppressed Flash, the Automatic White Balance function (⇒P.124) operates so that natural colors are captured along with the ambience of the available light.

- ⚠ If you are shooting in Suppressed Flash mode in dark conditions, use a tripod to prevent camera shake.
- ⚠ See P.26, 115 for information on the camera shake warning.



### Ⓜ Slow Synchro

This is a flash mode that uses a slow shutter speed. This allows you to take pictures of people at night that clearly show both your subjects and the night time backdrop.

- ⚠ The image may be overexposed when you shoot bright scenes.
- ⚠ Because a slow shutter speed is used, a tripod should be used to prevent camera shake.

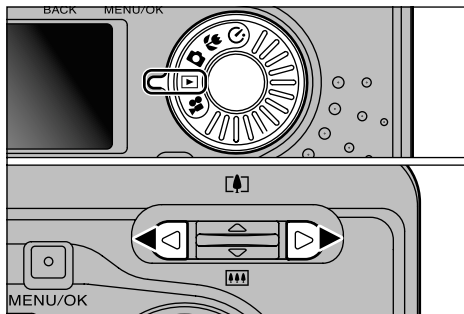

Set the Mode dial to “▶”.  
 Press “◀” and “▶” to move forward and backward respectively through your images.

⚠ When you set the Mode dial to “▶”, the last image shot is displayed.

## Fast Forwarding Images

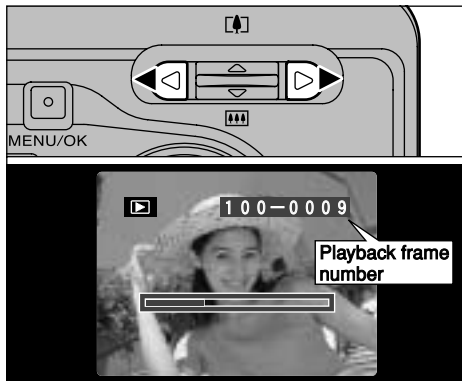

During playback, you can skip backwards or forwards through the images (the frame number increases or decreases) by holding down “◀” or “▶” for approximately 1 second.

The displayed image does not change, but a progress bar indicates the approximate playback location on the xD-Picture Card.

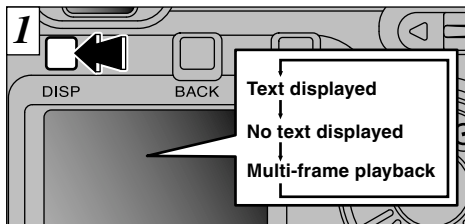

In playback mode, the display shown on the LCD monitor switches each time you press the “DISP” button. Press the “DISP” button until the multi-frame playback screen (9 frames) appears.

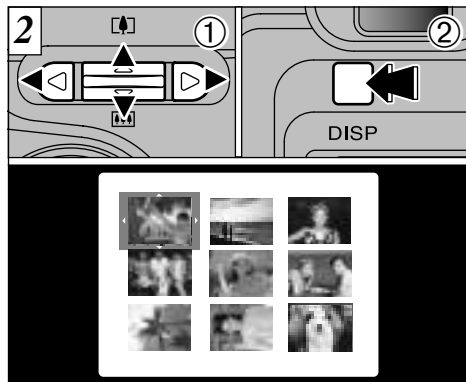

- ① Select a frame by using “◀”, “▶”, “▲” and “▼” to move the cursor (the orange box) to the desired frame. Press “▲” or “▼” several times to switch to the previous page or the next page.
- ② You can enlarge the selected image by pressing the “DISP” button again.

- ⚠ The LCD monitor text display disappears after approximately 3 seconds.
- ⚠ Playback zoom cannot be used with multi-frame playback.

This function is useful for things such as checking the focus of shots you have taken. To switch to the zoom screen, press “▲” during single-frame playback.

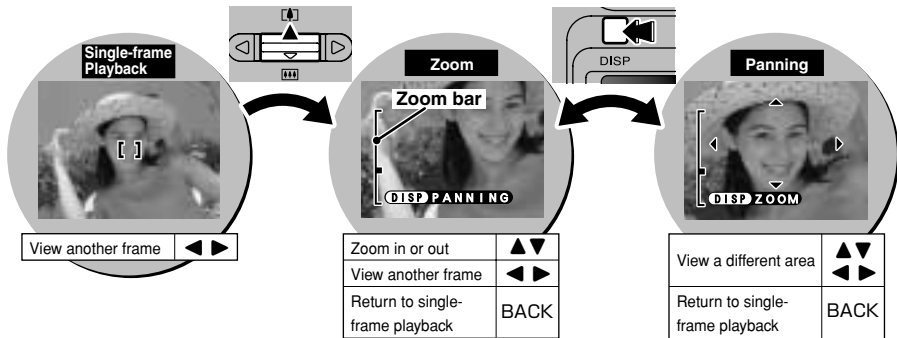

### ■ Maximum zoom scale

Model \ Quality	3M (2048 × 1536)	2M (1600 × 1200)	1M (1280 × 960)	0.3M (640 × 480)
FinePix A203	—	10×	8×	4×
FinePix A303	13×			

- ⚠ It may not be possible to play back images shot on other camera models.
- ⚠ Playback zoom cannot be used during multi-frame playback.

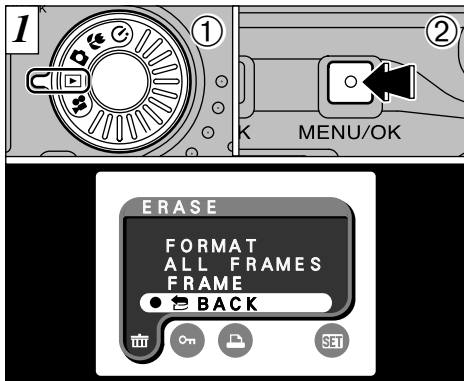

- ① Set the Mode dial to “▶”.
- ② Press the “MENU/OK” button to display the menu screen on the LCD monitor.

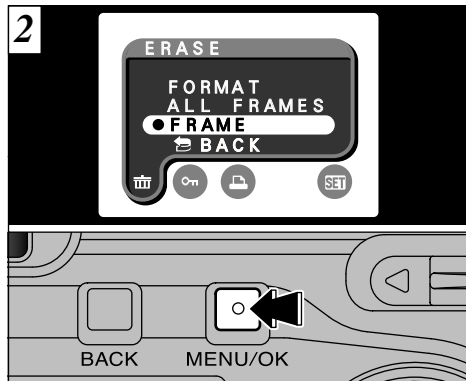

Select “FRAME” in the “” ERASE menu and press the “MENU/OK” button. See P.59 for more information on “ALL FRAMES” and “FORMAT”.

- ⚠ To revert to image playback without erasing the frame, select “BACK” and press the “MENU/OK” button.

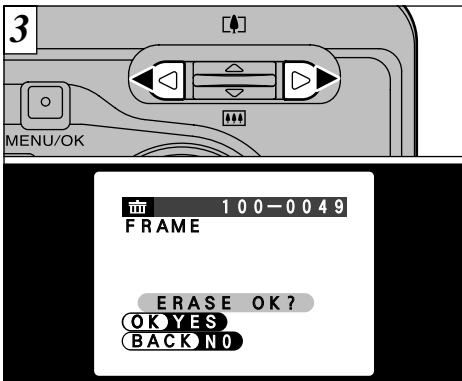

Press “◀” or “▶” to view the frame (individual file) you want to erase.

! Press the “BACK” button to cancel frame erasing.

Note that mistakenly erased images cannot be recovered.

You should copy important files that you want to keep to your computer.

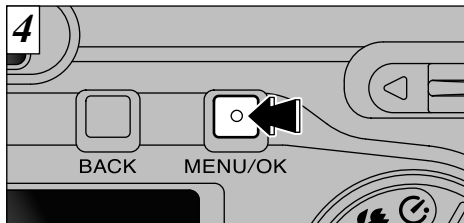

Pressing the “MENU/OK” button erases the frame (individual file) displayed. When the frame as been erased, the next frame is played back and “ERASE OK?” is displayed.

To erase another frame, repeat steps 3 and 4.

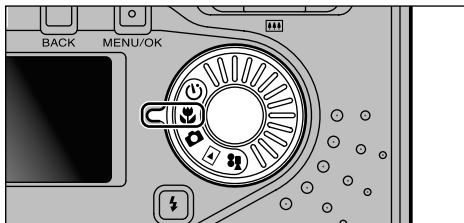

Setting the Mode dial to “” allows you to take close-up shots.

### ● Effective Photography Range

Approx. 10 cm to 80 cm (3.9 in.-2.6 ft.).

(Approx. 30 cm to 80 cm (1.0 ft.-2.6 ft.) when the flash is used)

- ⚠ When shooting in dark conditions, use a tripod to prevent camera shake.

If you use the viewfinder to take a picture in Macro mode, the field visible through the viewfinder does not match the field actually photographed because the viewfinder and lens are in different positions. Accordingly, you should use the LCD monitor to take pictures in Macro mode.

During macro photography, the following camera settings are applied:

- The lens is fixed at the wide-angle zoom setting and only the digital zoom can be used.
- The LCD monitor is automatically switched ON and cannot be switched OFF.

# 🕒 SELF-TIMER PHOTOGRAPHY

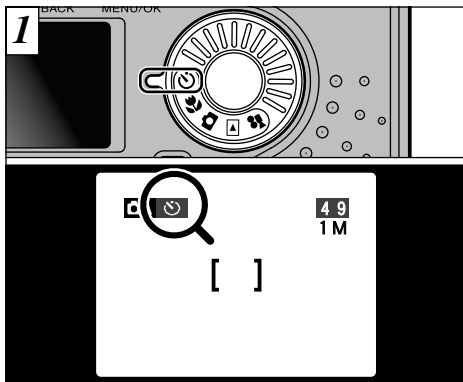

When you set the mode dial to “🕒”, “🕒” appears on the LCD monitor. In this mode, a timer runs for roughly 10 seconds before the shutter is released. Use this mode for shots such as photographs of yourself.

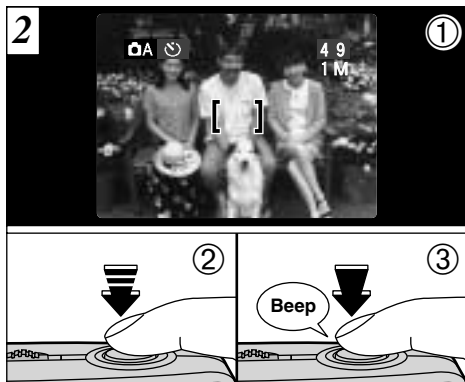

- ① Position the AF frame over your subject.
- ② Press the shutter button down half way to set the focus.
- ③ Without releasing the shutter button, press it down fully. The self-timer then starts running.

- ⚠ You can also use the AF/AE lock (➔P.30).
- ⚠ Be careful not to stand in front of the camera when you press the shutter button as this can cause focusing or exposure metering errors.

## SELF-TIMER PHOTOGRAPHY

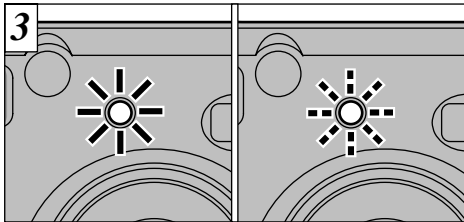

The self-timer lamp lights steadily for roughly 5 seconds and then blinks for another 5 seconds, after which the shot is taken.

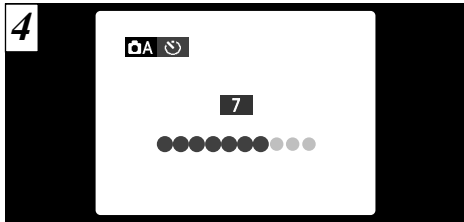

A counter on the LCD monitor counts down the time until the shot is taken.

**44**  To stop the self-timer once it has started running, press the "BACK" button.

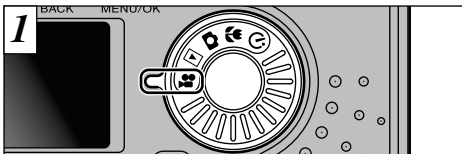

Set the Mode dial to “”.

● **Movie format:** Motion JPEG (→P.124)

**320** (320 × 240 pixels)

**160** (160 × 120 pixels)

selectable

10 frames per second

Without sound

■ **Number of seconds of recording per movie**

Model \ Quality	<b>320</b>	<b>160</b>
FinePix A203	20 sec.	80 sec.
FinePix A303	60 sec.	240 sec.

⚠ Depending on the available space on the xD-Picture Card, the available shooting time per movie may be shorter.

⚠ You cannot switch the LCD monitor off in this mode.

⚠ It may not be possible to play back your movie on other cameras.

⚠ See P.52 for information on changing the quality setting.

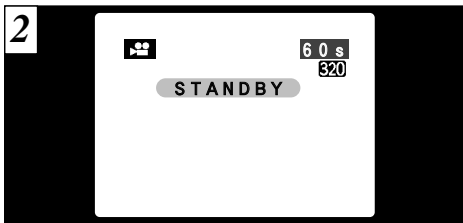

The available shooting time and the “**STANDBY**” message are shown on the LCD monitor.

■ **xD-Picture Card standard shooting time**

xD-Picture Card Capacity	<b>320</b>	<b>160</b>
DPC-16 (16 MB)	Approx. 94 sec.	Approx. 5 min.
DPC-32 (32 MB)	Approx. 191 sec.	Approx. 10.1 min.
DPC-64 (64 MB)	Approx. 6.4 min.	Approx. 20.2 min.
DPC-128 (128 MB)	Approx. 12.9 min.	Approx. 40.6 min.

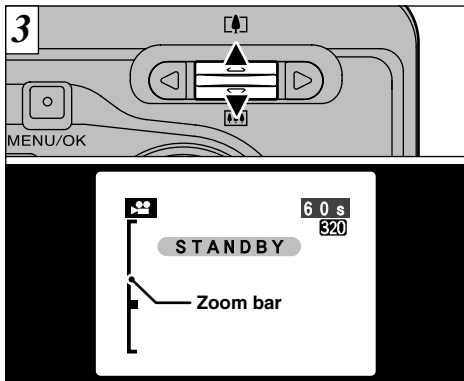

During movie shooting, the lens is fixed at the wide-angle zoom setting and only the digital zoom can be used.

Use “▲” or “▼” to zoom in and out. A zooming bar is displayed on the LCD monitor.

The focal distances and maximum zoom ratios for the digital zoom are shown below.

Model	Digital zoom focal distance (35 mm camera equivalent)	Maximum zoom scale
FinePix A203	Approx. 38 mm-95 mm	2.5×
FinePix A303	Approx. 38 mm-122 mm	3.2×

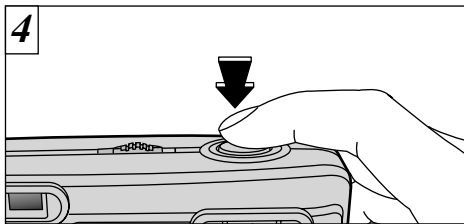

Shooting starts when you press the shutter button down fully.

- ! You do not need to hold down the shutter button.
- ! The focus is fixed at approximately 80 cm (2.6 ft.) to infinity.
- ! The white balance is fixed during shooting, but the exposure varies automatically to suit the scene being shot.
- ! The image shown on the LCD monitor before you take the shot may differ in its brightness, color, etc. from the image shown on the monitor during movie recording.

The white balance is set automatically when you press the shutter button.

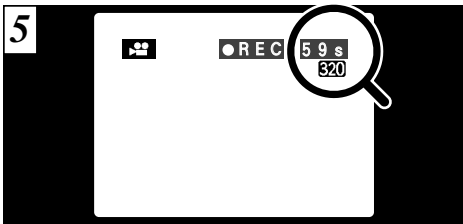

5 During shooting, "●REC" appears on the LCD monitor with a counter showing the remaining time displayed in the top-right corner.

! Once the remaining time runs out, movie recording automatically stops and the movie is stored on the xD-Picture Card.

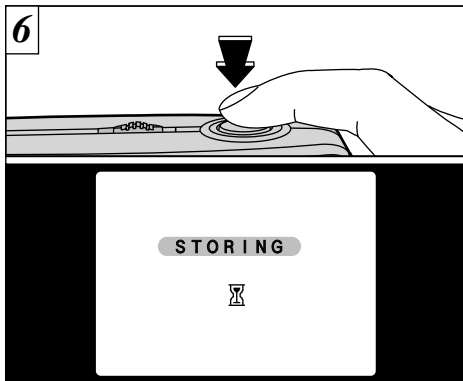

6 If you press the shutter button during shooting, shooting ends and the movie is stored on the xD-Picture Card.

! If you end shooting immediately after you start shooting, only 1 second of movie is shot.

# BASIC PHOTOGRAPHY MENU OPERATIONS

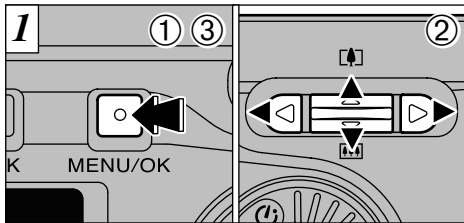

Set the Mode dial to “”, “”, “” or “”.

- ① Press the “MENU/OK” button to display the menu.
- ② Use “◀” or “▶” to select the menu item and “▲” or “▼” to change the setting.
- ③ Press the “MENU/OK” button to confirm the selection.

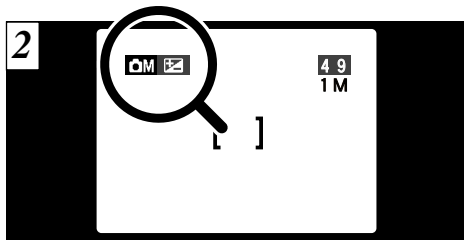

When you validate the settings, the respective icons appear at the top of the screen.  
(Example: When the EV (exposure compensation) is set in Manual mode.)

# SELECTING AUTO OR M MANUAL

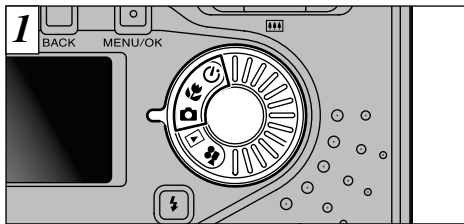

1 Set the Mode dial to “”, “ ” or “ ”.

## AUTO

This is the easiest mode for taking pictures and can be used in a wide range of conditions.

## MANUAL

This mode allows you to specify your own “EV (exposure compensation) and White Balance” settings.

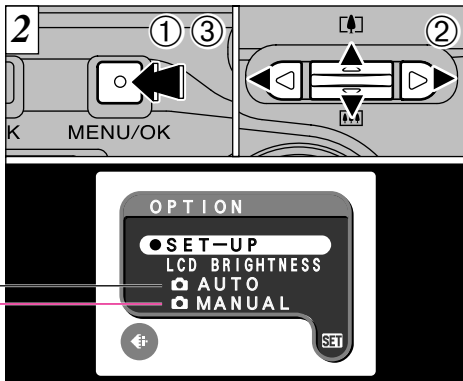

- 1 Press the “MENU/OK” button to display the menu.
- 2 Use “◀” or “▶” to select “ SET” OPTION and then use “▲” or “▼” to select “ AUTO” or “ MANUAL”.
- 3 Press the “MENU/OK” button to confirm the selection.

3

# PHOTOGRAPHY MENU OPTIONS

## Still/Macro/Self Timer Mode

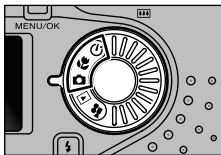

When you press the “MENU/OK” button in the “”, “” or “” mode, one of the menu screens shown below appears, allowing you to specify the respective settings.

Selecting the “ MANUAL” setting allows you to specify the “EV (exposure compensation)” and “WHITE BALANCE” settings.

### AUTO

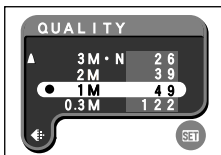

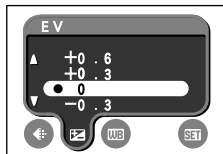
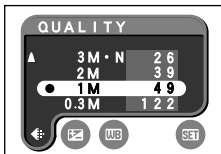

You can switch between AUTO and MANUAL in “OPTION”.

### MANUAL

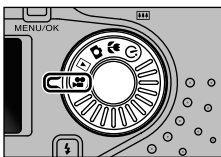

## Movie Mode



If you press the “MENU/OK” button in “” mode, the menu screens shown below appear, allowing you to specify the respective settings.

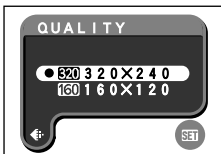

3

Use the “” QUALITY setting to specify the number of recorded pixels.

### ■ FinePix A203: Photography (, , )

Quality	Usage
2M · F (1600×1200)	For printing
2M · N (1600×1200)	
1M (1280×960)	For the Internet
0.3M (640×480)	

### ■ FinePix A303: Photography (, , )

Quality	Usage
3M · F (2048×1536)	For printing
3M · N (2048×1536)	
2M (1600×1200)	For the Internet
1M (1280×960)	
0.3M (640×480)	

### ■ FinePix A203/FinePix A303: Movie ()

<b>320</b> (320×240)	—
<b>160</b> (160×120)	

### FinePix A203: Photography (, , )

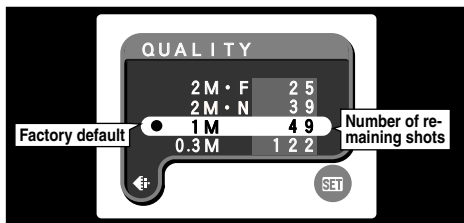

Any of 4 settings can be selected.  
Select the setting that best suits your needs.

#### <Examples>

#### ● To print at A6 (postcard) to A5 size

→ 2M · F or 2M · N

\* Select 2M · F for better quality and 2M · N for more shots.

Normally the 2M · N setting provides sufficiently high quality for printing.

#### ● To print at A7 (half postcard) to A6 (postcard) size

→ 1M

#### ● For an image attached to E-mail or used on a website

→ 0.3M

## FinePix A303: Photography (📷, 🌿, 🌙)

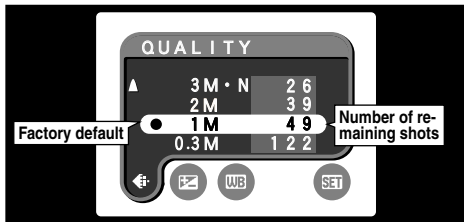

Any of 5 settings can be selected.  
Select the setting that best suits your needs.

### <Examples>

- **To print at A4 size**
  - ➔ 3M · F or 3M · N
  - \* Select 3M · F for better quality and 3M · N for more shots.
  - Normally the 3M · N setting provides sufficiently high quality for printing.
- **To print at A6 (postcard) to A5 size**
  - ➔ 2M
- **To print at A7 (half postcard) to A6 (postcard) size**
  - ➔ 1M
- **For an image attached to E-mail or used on a website**
  - ➔ 0.3M

## FinePix A203/FinePix A303: Movie (🎥)

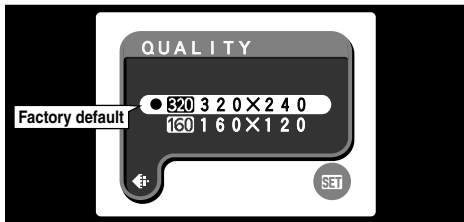

You can choose from 2 image sizes for movies.  
Select “320” for better quality or “160” for longer shooting times.

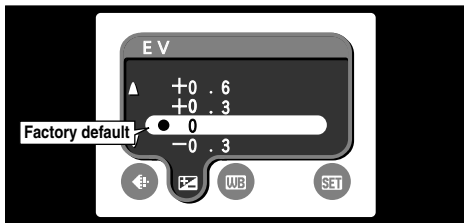

This mode can be selected in the “**Ⓜ**” photography mode.

Use the Brightness setting to obtain the optimum image brightness (exposure) when the subject is much brighter or darker than the background.

- **Correction range:** 13 steps  
(-2.1 EV to +1.5 EV in 0.3 EV increments)  
See P.124 for more information on EV.

⚠ The Brightness setting is disabled in the following situations:

- When the flash is used in Auto or Red-Eye Reduction mode.
- When dark scenes are shot in Forced Flash mode.

### ◆ Subjects for Which Exposure Adjustment is Particularly Effective ◆

#### Guide to using + (positive) compensation

- Copying of printed text (black characters on white paper) (+1.5 EV)
- Backlit portraits (+0.6 EV to +1.5 EV)
- Locations with very bright backgrounds or strong reflections, such as ski resorts: +0.9 EV
- Shots made up predominantly of sky (+0.9 EV)

#### Guide to using - (negative) compensation

- For spotlight subjects, particularly against a dark background: -0.6 EV
- Copying of printed text (white characters on black paper) (-0.6 EV)
- Scenes with low reflectivity, such as shots of pine trees or dark foliage (-0.6 EV)

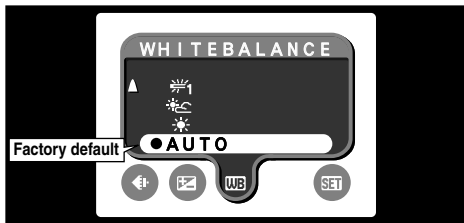







This mode can be selected in the “**☑**” photography mode.

Change the white balance setting when you want to take a picture with the white balance fixed for the surroundings and lighting when the picture is taken.

In Auto mode, the correct white balance may not be obtained for subjects such as close-ups of people’s faces and shots taken under a special light source. In such situations, select the correct white balance for the light source. See P.124 for information on the white balance.

**AUTO:** Automatic adjustment  
(Shooting to show the ambience of the light source)

-  : Shooting outdoors in fine weather
-  : Shooting in shade
-  : Shooting under “Daylight” fluorescent lamps
-  : Shooting under “Warm White” fluorescent lamps
-  : Shooting under “Cool White” fluorescent lamps
-  : Shooting in incandescent light

\* The white balance setting (unless it is a Custom White Balance setting) is ignored when you use the flash. To achieve the desired effect in your shot, press the flash back down to suppress flash operation (➡P.36).

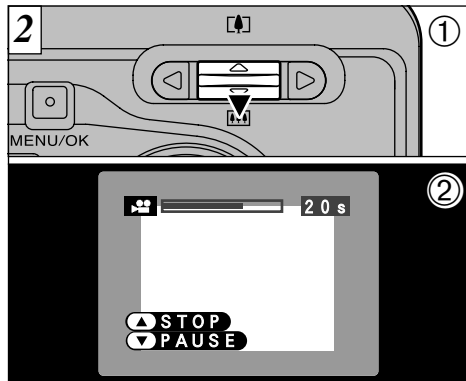
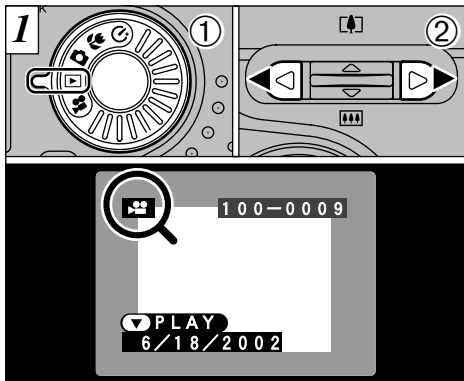



- ① Set the Mode dial to “▶”.
- ② Use “◀” or “▶” to select the movie file.

- ① Press “▼” to play the movie.
- ② The LCD monitor shows the playback time and a playback progress bar.

⚠ Movies cannot be played back using multi-frame playback. Use the “DISP” button to revert to normal playback.

⚠ If the subject of the movie is very bright, white streaks may appear on the image during playback. This is normal and is not a fault.

## ■ Playing back movies

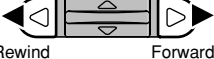
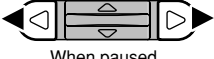
	Control	Description
Playback		The movie automatically stops when playback ends.
Pause/Resume		Pauses the movie during playback. Press this button again to resume playback.
Stop		Stops playback. * Press “◀” or “▶” while movie playback is stopped to go back to the previous file or advance to the next file respectively.
Fast forward/Rewind	 Rewind                      Forward	Press these during playback to skip forwards or backwards through the movie.
Skip playback	 When paused	<ul style="list-style-type: none"> <li>• Each time you press “◀” or “▶” when the movie is paused, the movie advances or goes back one frame.</li> <li>• Hold down the button to move through the frames quickly.</li> </ul>

### ◆ Playing back movie files ◆

- It may not be possible to play back movies shot on other camera models.
- To play back movie files on a computer, save the movie file on the xD-Picture Card to the computer's hard disk and then play back the saved file.
- Video files contain large amounts of data. Depending on the performance of the computer, movies may not run smoothly if the computer cannot process the images quickly enough.
- If you play back your movies on a computer or a different camera model, they may run slightly faster than normal.

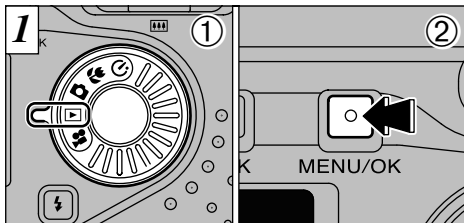

- ① Set the Mode dial to “▶”.
- ② Press the “MENU/OK” button to view the menu screen.

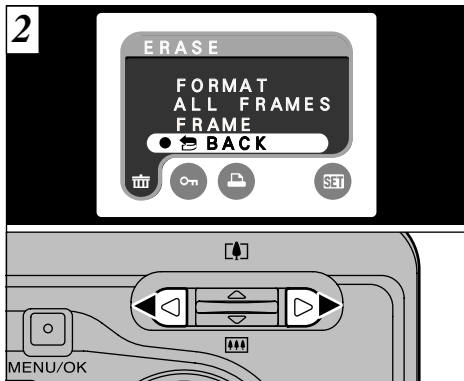

Use “◀” or “▶” to select “ ERASE.

Note that mistakenly erased images cannot be recovered.

You should copy important files that you want to keep to your computer.

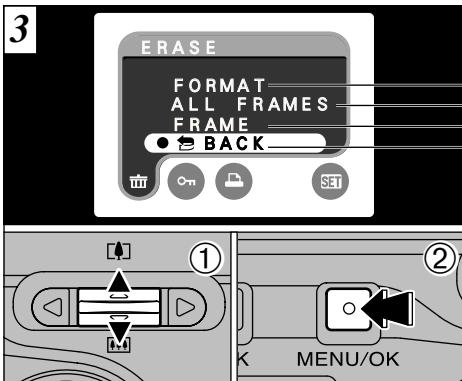

- ① Use “▲” or “▼” to select “FRAME”, “ALL FRAMES” or “FORMAT”.
- ② Press “MENU/OK” button to confirm your selection.

## FORMAT

Erases all the images. Because formatting also erases protected files, check carefully before formatting a card and copy any files that you want to keep onto other media, such as your hard disk.

## ALL FRAMES

Erases all unprotected images. You should copy important files that you do not want to be erased to your computer or other media.

## FRAME

Erases only the selected image.

## BACK

Returns to playback without erasing any files.



## FRAME



- ① Press “◀” or “▶” to select the image to be erased.
  - ② Press the “MENU/OK” button to erase the displayed image.
- To erase another image, repeat steps ① and ②. When you have finished erasing images, press the “BACK” button.

! Images with “[ I PROTECTED FRAME ]” displayed cannot be erased. Unprotect the image before erasing it.

## ALL FRAMES



Press the “MENU/OK” button to erase all the unprotected images.

If “ [ DPOF SPECIFIED. ERASE OK ? ] ”

“ [ DPOF SPECIFIED. ERASE ALL OK ? ] ” appears, press the “MENU/OK” button again to erase the image.

## FORMAT

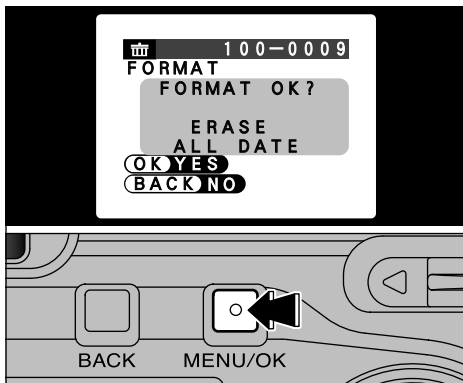

Press the “MENU/OK” button to erase all the images and initialize the xD-Picture Card. Protected images are also erased.

- ! If the “[I CARD ERROR]”, “[I WRITE ERROR]”, “[I READ ERROR]” or “[I CARD NOT INITIALIZED]” message appears, refer to P.114, 115 before formatting the xD-Picture Card and take the appropriate measures.

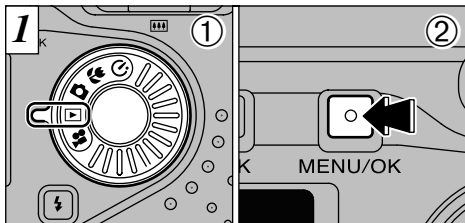

- ① Set the Mode dial to “▶”.
- ② Press the “MENU/OK” button to view the menu screen.

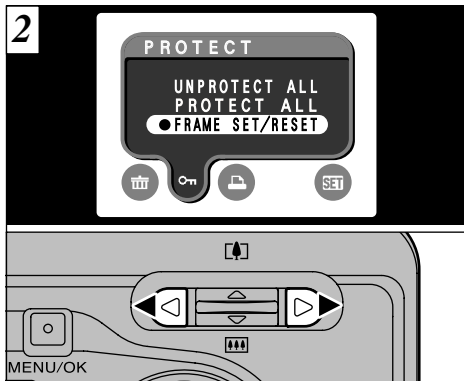

Use “◀” or “▶” to select “” PROTECT.

Protection is a setting that prevents images from being accidentally erased. However, “FORMAT” erases all images, regardless of protected or not (→ P.61).

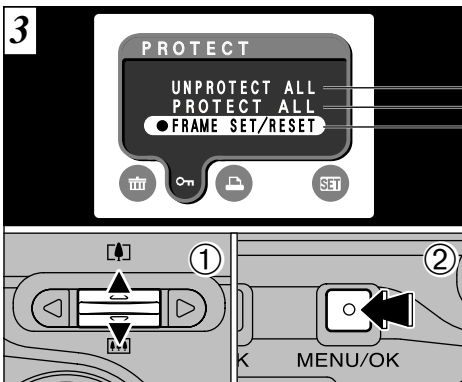

- ① Use “▲” or “▼” to select “FRAME SET/RESET”, “PROTECT ALL” or “UNPROTECT ALL”.
- ② Press “MENU/OK” button to confirm your selection.

### UNPROTECT ALL

Unprotects all the images.

### PROTECT ALL

Protects all the images.

### FRAME SET/RESET

Protects or unprotects only the selected image.

## FRAME SET/RESET



- ① Press “◀” or “▶” to select the image to be protected.
- ② Press the “MENU/OK” button to protect the displayed image.

To protect another file, repeat steps ① and ②.  
To finish protecting files, press the “BACK” button.

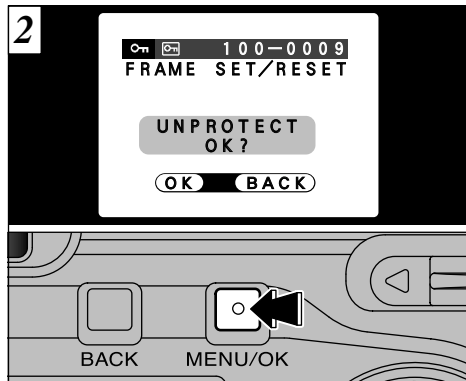

To remove the protection, press the “MENU/OK” button again.

## PROTECT ALL



Pressing the "MENU/OK" button protects all the images.

## UNPROTECT ALL



Pressing the "MENU/OK" button unprotects all the images.



DPOF stands for Digital Print Order Format and refers to a format that is used for recording printing specifications for images shot using a digital camera on media such as xD-Picture Card. The recorded specifications include information on which frames are to be printed.

This section gives a detailed description of how to order your prints with the FinePix A203/FinePix A303.

On the FinePix A203/FinePix A303, you can specify only one print per image in the DPOF settings.

- \* Note that some printers do not support date and time imprinting or specification of the number of prints.
- \* Note that the warnings shown below may be displayed while you are specifying the prints.

DPOF SPECIFIED. ERASE OK ?

DPOF SPECIFIED. ERASE ALL OK ? (→P.60)

When you erase the image, the DPOF setting for that image is deleted at the same time.

RESET DPOF OK ? (→P.70)

If you load a xD-Picture Card that contains frames specified for printing on another camera, those print specifications are all reset and replaced by the new print specifications.

! DPOF FILE ERROR (→P.116)

Up to 999 frames can be specified on the same xD-Picture Card.

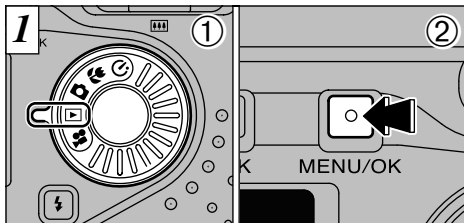

- ① Set the Mode dial to “▶”.
- ② Press the “MENU/OK” button to display the menu screen.

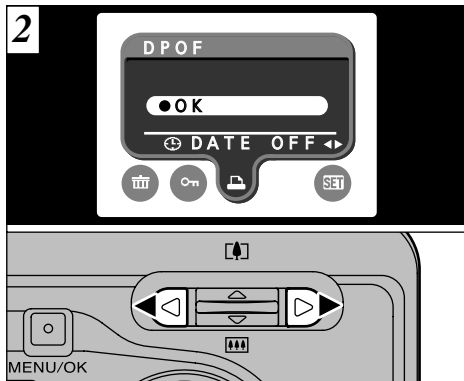

Use “◀” or “▶” to select “4

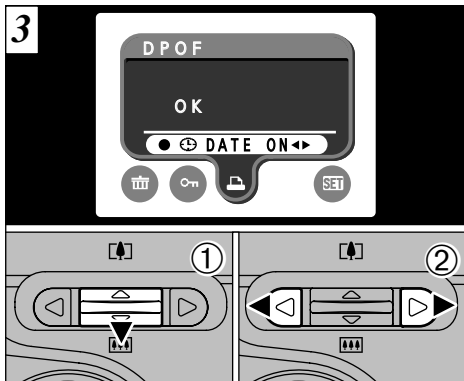

- ① Use “▼” to select “☺DATE”.
- ② Use “◀” and “▶” to select “DATE ON” or “DATE OFF”.

The selected setting is then valid for all frames with DPOF settings.

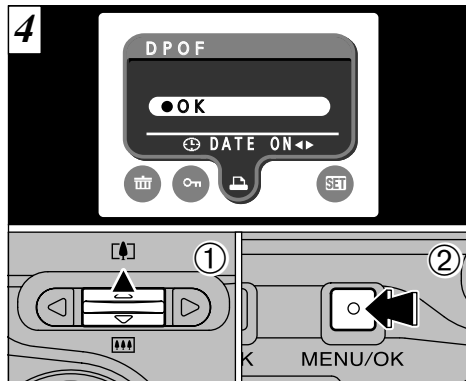

- ① Press “▲” to select “OK”.
- ② Press the “MENU/OK” button.

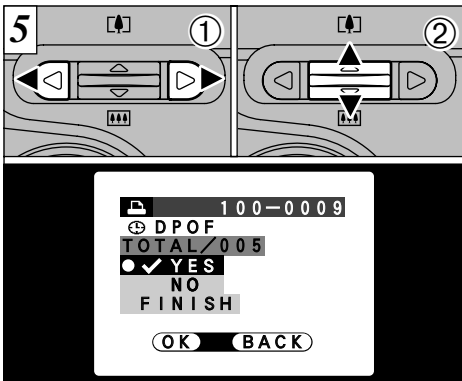

- ① Use “◀” or “▶” to display the frame for which you want to specify DPOF settings.
- ② Press “▲” or “▼” to set “YES” for the frame to be printed and then press the “MENU/OK” button or “▶”.

To specify more DPOF settings, repeat steps ① and ②.

- ⚠ DPOF settings cannot be specified for movies.
- ⚠ “TOTAL” shows the total number of frames for which prints have been ordered.

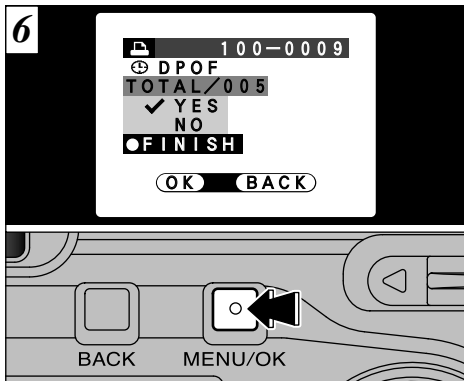

**When you have finished the settings, always select “FINISH” and press the “MENU/OK” button.**

If you press the “BACK” button, no DPOF settings are specified.

- ⚠ You can only specify one print per frame in the DPOF settings. Note also that you can specify prints for up to 999 frames on the same xD-Picture Card.

Continued over page...



Pressing the “MENU/OK” button confirms the DPOF settings.

Pressing the “BACK” button returns you to the settings screen **5**.

Pressing the “MENU/OK” button confirms all the settings.

◆ DPOF settings cannot be added to or changed. ◆

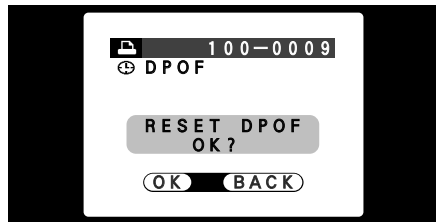

If you select a frame for which DPOF settings have already been specified, the “RESET DPOF OK?” message appears.

Pressing the “MENU/OK” button erases all the DPOF settings already specified. You must then specify the DPOF settings again.

- ! Press the “BACK” button to leave the previous settings unchanged.
- ! During playback, check that the “” icon is displayed for the previous settings.

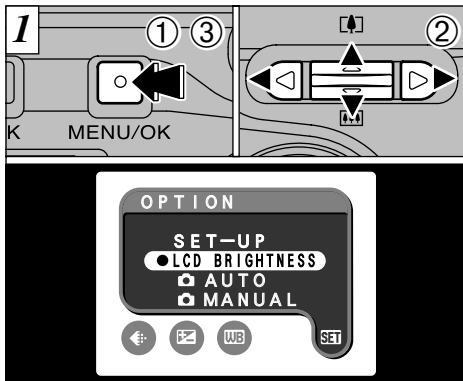

- ① Press the “MENU/OK” button to display the menu screen.
- ② Press “◀” or “▶” to select “SET” OPTION and then press “▲” or “▼” to select “LCD BRIGHTNESS”.
- ③ Press the “MENU/OK” button.

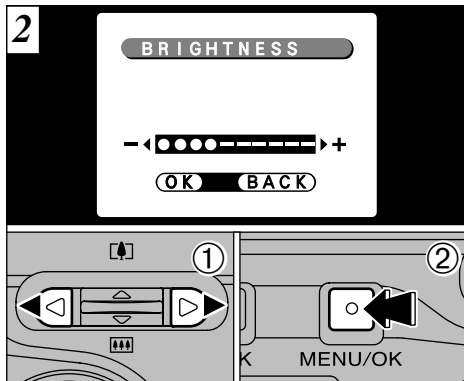

- ① Use “◀” or “▶” to adjust the LCD monitor brightness.
- ② Press the “MENU/OK” button.

⚠ To exit this procedure without changing the settings, press the “BACK” button.

## SET USING SET-UP

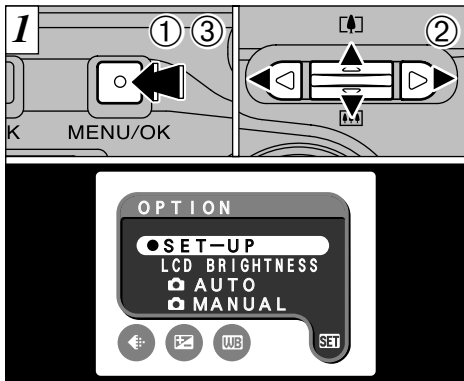

- ① Press the “MENU/OK” button to display the menu screen.
- ② Press “◀” or “▶” to select “SET” OPTION and then press “▲” or “▼” to select “SET-UP”.
- ③ Press the “MENU/OK” button.

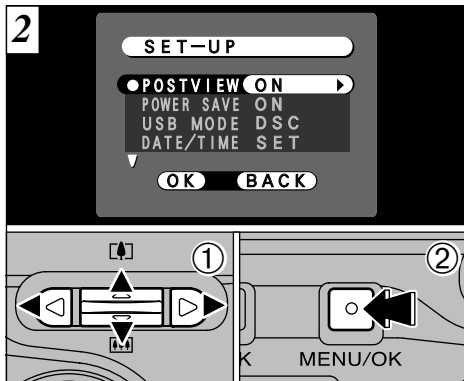





- ① Press “▲” or “▼” to select a menu option and then press “◀” or “▶” to change the setting.
- ② Press the “MENU/OK” button.



! Press “▶” for “DATE/TIME” or “RESET ALL”.

## ■ List of Settings

The options available in the settings menus vary depending on the mode, as shown in the table below.

 Still Photography mode	 Movie mode	 Playback mode
 AUTO  MANUAL LCD BRIGHTNESS (P.71) SET-UP	— — LCD BRIGHTNESS (P.71) SET-UP	— — LCD BRIGHTNESS (P.71) SET-UP

## ■ SET-UP Menu Options (Date/time setting, etc.)

Settings	Display	Factory default	Explanation
POSTVIEW	ON/OFF	ON	This option specifies whether or not an image checking screen (photography results) is displayed after you take a shot. The photographed image is displayed for a few moments and then automatically recorded.
POWER SAVE	ON/OFF	ON	If the camera is not used for approximately 30 seconds, this function temporarily switches off the LCD monitor. See P.74 for details.
USB MODE	DSC/PC CAM	DSC	See P.75 for details.
DATE/TIME	SET	—	Use this option to correct the date or time. See P.15 for details.
 LCD	ON/OFF	ON	Use this option to specify whether the LCD monitor is automatically switched ON or OFF when the Mode dial is set to “  ”.
BEEP 	LOW/HIGH/OFF	LOW	Allows you to set the camera's operating sound.
LANGUAGE	ENGLISH/FRANCAIS/ DEUTSCH	ENGLISH	Select English, French or German as the language used for screen display.
RESET ALL	OK	—	This resets all the camera settings (including the photography and playback menu settings) other than DATE/TIME and LANGUAGE to the factory default values set at shipment.

## SET-UP **SET** POWER SAVE

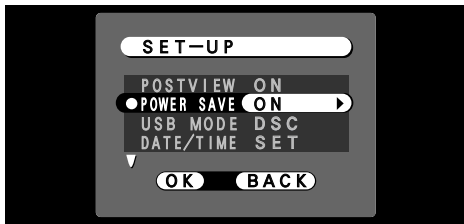

### ●Power saving “ON” (default setting)

Power consumption is kept to a minimum to prevent battery depletion. You should select the “ON” setting when you are using alkaline batteries.

- If the camera is not used for approximately 30 seconds, the LCD monitor switches off temporarily to reduce power consumption (Sleep mode).
- Once the camera is in Sleep mode, if it is left unused for a further 90 seconds, it is automatically switched off.
- The charging time for the flash increases slightly because the flash charging power is reduced.

### ●Power saving “OFF”

Batteries are more likely to run flat since no power reduction measures (sleep mode, etc.) are used. However, this function automatically switches the camera off if the camera is not used for approximately 2 minutes.

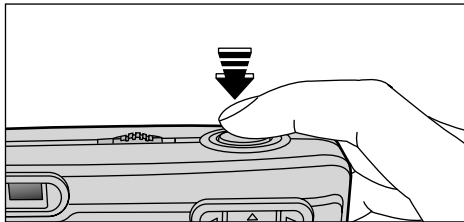

When the camera is in Sleep mode, pressing any button on the camera will switch the LCD monitor back on. You can take a picture even while the LCD monitor is switched off simply by pressing the shutter button.

- ! If you press the shutter button down halfway and then release it, the screen may go dark briefly because the flash is charging.
- ! The Power Save and Auto Power Off functions are disabled during USB connection.

The Sleep function does not operate when the LCD monitor is switched off, during setup, or in Playback mode, but the camera still switches off automatically if it is not used for 2 minutes.

# 6 Software Installation

## 6.1 The Software Components

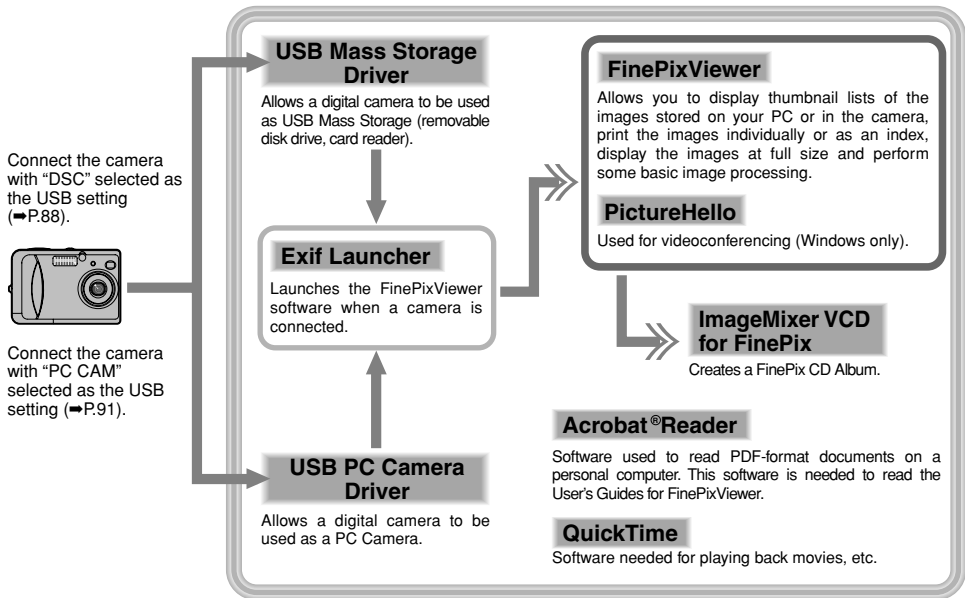

\* Note that the software configuration differs slightly depending on your operating system.

## 6.2 Installation on a Windows PC

### 6.2.1 Load the CD-ROM into your PC

**Do not connect the camera to your PC until the software installation is completed.**

#### 1. Switch on your PC and start up Windows.

\* If you have already switched on your PC, restart your PC at this point.

#### **NOTE**

Users of Windows 2000 or Windows XP should log in using a system administrator account (e.g. "Administrator").

#### 2. Quit all other active applications until no applications are shown in the taskbar.

#### **NOTE**

If a "----.dll file not found." message appears during installation, there is another application running in the background. Forcibly shut down the application. Refer to your Windows manuals for information on how to forcibly shut down an application.

#### 3. Load the enclosed CD-ROM into the CD-ROM drive. The installer starts up automatically.

#### 4. The Setup screen appears. Click the [Installing FinePixViewer] button.

\* For more information on what is installed, click the [Read Me First] button and [Using FinePixViewer] button.



## Launching the Installer Manually

1. **Double-click the “My Computer” icon.**  
\* Windows XP users should click “My Computer” in the “Start” menu.
2. **Right-click “FINEPIX” (CD-ROM drive) in the “My Computer” window and select “Open”.**
3. **Double-click “SETUP” or “SETUP.exe” in the CD-ROM window.**



SETUP



SETUP.exe

- \* The way file names are displayed differs as described below depending on your computer settings.
  - File extensions (3-letter suffixes indicating the file type) may be shown or hidden. (e.g. Setup.exe or Setup)
  - Text may be shown normally or all in uppercase (e.g. Setup or SETUP).

## 6.2.2 From FinePixViewer installation to restart

1. **Pre-installation checking begins. If any warning messages appear, follow the instructions given on the screen.**



- \* The “Add New Hardware Wizard” may be hidden behind the “Note” message. Check the taskbar, move the message window and then click the [Cancel] button.



2. A confirmation message appears asking whether you want to continue with the installation. Click the [OK] button.

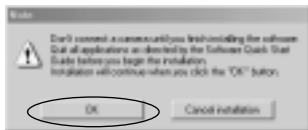

3. The software version is checked. If the window shown below appears, click the [OK] button to uninstall the software.

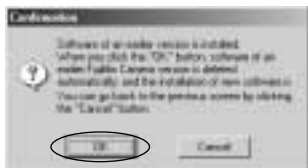

4. The USB drivers are installed.

### 5. Install FinePixViewer.

- ① FinePixViewer installation begins and notes and warnings are displayed. When you have confirmed these, click the [Next >] button.
- ② The User License Agreement for this software is displayed. Read the agreement carefully and then, if you agree to the terms of the Agreement, click the [Yes] button. If you click the [No] button, the software is not installed.



- ③ Check the installation destination folder and then click the [Next >] button.
- ④ "Confirmation" screen shown may appear. To continue with the settings, click the [Yes] button.

**6. Install QuickTime as directed by the on-screen instructions.**

\* If you have already installed QuickTime version 5.0.2 or later, this installation is not performed.



Click [Agree] button in the “Software License Agreement” window.

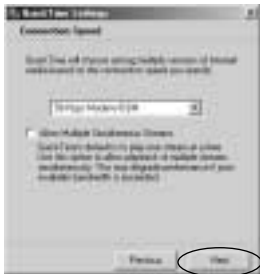

If the “Connection speed” window appears, set the correct speed for your environment of connection and then click the [Next] button.

\* If you do not know your connection speed, simply click the [Next] button.

**7. Install NetMeeting as directed by the on-screen instructions.**

\* If NetMeeting 3.01 or later is already installed on your PC, this installation is not performed.

**8. Install ImageMixer VCD for FinePix as directed by the on-screen instructions.**

**9. Close the “Readme” window.**

**10. Install WINASPI as directed by the on-screen instructions.**

**11. Install Windows Media Player as directed by the on-screen instructions and then restart your PC.**

\* If the latest version of the software is already installed on your PC, this installation is not performed. When next screen appears, click the [Restart] button.

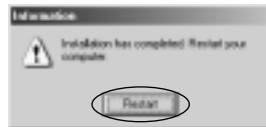

In Windows Media Component Setup window, tick the “I have read the Privacy Statement” checkbox and then click the [Next >] button.

When you click the [Finish] button, your PC is restarted.

12. After you restart your PC, install DirectX as directed by the on-screen instructions and then restart your PC again. If the latest version of DirectX is already installed on your PC, this installation is not performed.
13. After you restart your PC, the “FinePixViewer installation completed” message appears. Click “Using FinePixViewer” to view the basic FinePixViewer functions.



14. To install Acrobat Reader, click “Install Acrobat Reader”.\*

\* You should install Adobe Systems’ Acrobat Reader software to read the FinePixViewer User’s Guide (PDF).

If you already have the latest version installed, this step is not required.

15. Proceed with the installation as directed by the on-screen instructions.

### ■ To install Acrobat Reader later...

1. Open the “My Computer” window, right-click the CD-ROM icon and select “Open” to view the contents of the CD-ROM.



2. Double-click “ACROREAD” → “ENGLISH” folder.
3. Double-click “ar505enu.exe”.
4. Proceed with the installation as directed by the on-screen instructions.

## 6.3 Installation on a Mac OS 8.6 to 9.2

### 6.3.1 Check the system software settings

#### ■ Enable File Exchange

Check whether File Exchange is active.

To use an xD-Picture Card that is supported by the camera, the File Exchange utility supplied with Mac OS must be running.

#### 1. Switch on your Macintosh and start up Mac OS 8.6 to 9.2.

#### NOTE

Do not connect the camera to your Macintosh until the software installation is completed.

#### 2. Select the Extension Manager in the Control Panel and check that the File Exchange check box is ticked. If not, click in the box so that an appears and then restart your Macintosh.

### 6.3.2 From FinePixViewer installation to restart

#### 1. When you load the enclosed CD-ROM into the CD-ROM drive, the “FinePix” window automatically opens.

#### NOTE

If the “FinePix” window does not open automatically, double-click the CD-ROM icon.

#### 2. Double-click “Installer for MacOS8.6-9.x” to launch the Installer.

#### 3. The Installer setup screen appears. Click the [Installing FinePixViewer] button.

\* For more information on what is installed, click the [Read Me First] button and [Using FinePixViewer] button.

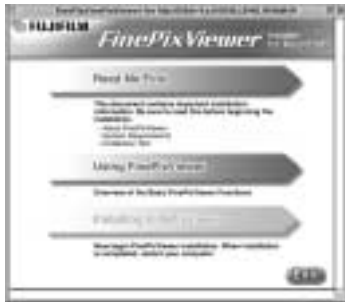

#### 4. A confirmation message appears asking whether you want to continue with the installation. Click the [OK] button.

#### 5. The User License Agreement for this software is displayed. Read the agreement carefully and then, if you agree to the terms of the Agreement, click the [Yes] button. If you click the [No] button, the software is not installed.

## 6. Select the installation destination for FinePixViewer and ImageMixer VCD for FinePix.

- 1 Click the [Open] button to open the installation destination folder.

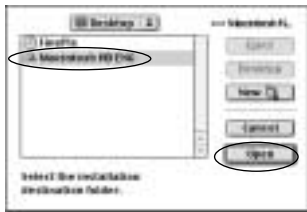

- 2 Click the [Save] button.

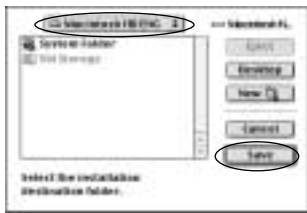

## 7. Install QuickTime as directed by the on-screen instructions and then restart your Macintosh.

- \* If you have already installed QuickTime version 5.0.2 or later, this installation is not performed.



Click [Agree] button in the "License" window.

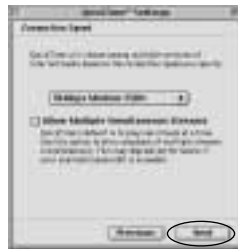

If the "Connection Speed" window appears after you restart your Macintosh, set the correct speed for your environment of connection and then click the [Next] button.

- \* If you do not know your connection speed, simply click the [Next] button.

8. After you restart your Macintosh, the “FinePixViewer installation completed” message appears. Click “Using FinePixViewer” to view the basic FinePixViewer functions.



9. To install Acrobat Reader, click “Install Acrobat Reader”.\*

\* You should install Adobe Systems’ Acrobat Reader software to read the FinePixViewer User’s Guide (PDF).

If you already have the latest version installed, this step is not required.

10. Proceed with the installation as directed by the on-screen instructions.

■ To install Acrobat Reader later...

1. Double-click the “FinePix” CD-ROM to open the CD-ROM window.
2. Double-click “FinePixViewer for Mac OS 8.6-9.x” → “Acrobat Reader” → “English” folder.
3. Double-click “English Reader Installer”.
4. Proceed with the installation as directed by the on-screen instructions.

## 6.4 Installation on a Mac OS X

### 6.4.1 From FinePixViewer installation to restart

Only FinePixViewer is installed on Mac OS X.

#### **NOTE**

AVI movies cannot be played back on version 10.0.4.

1. **Switch your Macintosh on and start up Mac OS X. Do not launch any other applications.**
2. **Load the enclosed CD-ROM into the CD-ROM drive. The “FinePix” window opens.**

#### **NOTE**

If the “FinePix” window does not open automatically, double-click the CD-ROM icon.



3. **Double-click “Installer for MacOS X”.**



4. **Click the “” icon.**



5. **Enter the administrator name and password. Then click the [OK] button.**



6. **Click the [Continue] button.**
7. **Quit any other programs that are running and then click the [Continue] button.**
8. **Click [Continue] button in the “Software License Agreement” window.**

9. Select the Mac OS X startup disk as the installation destination and click the [Continue] button.



10. Click the [Install (upgrade)] button.
11. When you have completed the installation, click the [Restart] button.



# 7 Camera Connection

The “Camera Connection” section explains how to connect the camera to your computer using the special USB cable and describes the functions you can use once the camera and computer are connected.

If the power cuts out during data transmission, the data will not be transmitted correctly. Always use the AC power adapter when connecting the camera to a computer.

## The first time you connect the camera to your computer by referring Section 6

You must install all of the software before connecting the camera to your computer.



CD-ROM  
(Software for FinePix SX)

## ■ DSC (Mass storage device) Mode

This mode provides a simple way to read images from an xD-Picture Card and store images on to an xD-Picture Card (➔P.88).

## ■ PC CAM (PC Camera) Mode

This function allows you to conduct videoconferencing sessions between PCs connected to the Internet (➔P.91).

- \***Videoconferencing (“PictureHello”) is not supported on Macintosh computers.**
- \*Connection is only possible with a FUJIFILM camera equipped with a “PC Camera” function.

For more information on using the software, refer to “How to use FinePixViewer” in the HELP menu which was installed from the CD-ROM.



## 7.1 Using the optional AC Power adapter

Always use a FUJIFILM AC Power Adapter AC-3V (➡P.106).

Use the AC power adapter to avoid losing power at inconvenient times, such as when you are downloading photographed images to your computer. Using the AC power adapter also allows you to take pictures and play back images without worrying about depleting the batteries.

\*See P.111 for notes on using the AC power adapter.

\*Only connect or disconnect the AC power adapter when the camera is switched off.

Connecting or disconnecting the AC power adapter while the camera is switched on temporarily interrupts the power supply to the camera, so that images or movies being shot at the time are not recorded. Failing to switch the camera off first can also result in damage to the xD-Picture Card or malfunctions during PC connection.

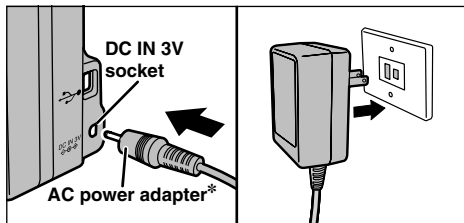

\* Sold separately

Check that the camera is switched off. Plug the AC power adapter connector into the “DC IN 3V” socket and then plug the AC power adapter into the power outlet.

- \*The socket-outlet shall be installed near the equipment and shall be easily accessible.
- \*The shape of the plug and socket-outlet depends on the country of use.

Connecting the AC power adapter does not allow you to charge the Ni-MH batteries. Use the optional charger (➡P.106) to charge the Ni-MH batteries.

## 7.2 Use at DSC mode

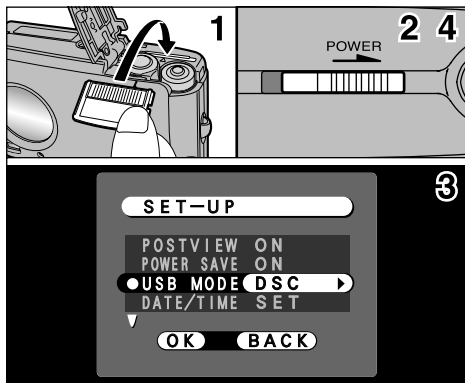

1. Load an xD-Picture Card containing photographed images into your camera. Plug the AC power adapter connector into the DC IN 3V socket on the camera and then plug the adapter itself into the main power outlet.
2. Slide the power switch to the side to turn the camera on.
3. Set the “USB MODE” setting in the “SET-UP” menu to “DSC” (⇒P.72, 73).
4. Slide the Power switch to the side to turn the camera off.

\*It is recommended that you connect the AC Power Adapter AC-3V (sold separately) (⇒P.87). Constant power supply will prevent successful data transfer from trouble caused by power supply.

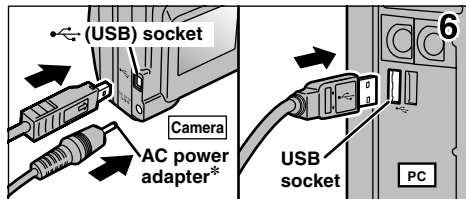

\* Sold separately

5. Switch your PC on.
6. Use the special USB cable to connect the camera to your computer.
7. Switch the camera on.

If you are using a Windows PC, the driver settings are specified automatically when installation is completed. No further action is required.

Always use the prescribed procedure when disconnecting or switching off the camera (⇒P.94).

- \*On Windows XP and Mac OS X, you must specify the automatic launch settings the first time you connect the camera to your computer.
- \*Take care to ensure that the special USB cable is connected the correct way around and that the plugs are pushed fully into the connection sockets.

## ■ Camera Operation

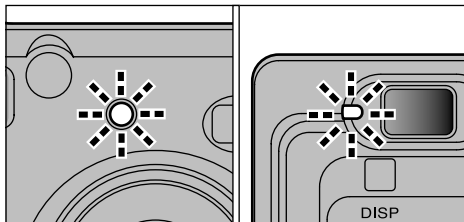

- When the camera and computer are exchanging data, the self timer lamp flashes and the viewfinder lamp flashes alternately green and orange.
  - “DSC” appears on the screen.
  - Power Save and Auto Power Off are disabled during USB connection.
- \*Before replacing the xD-Picture Card, always disconnect the camera from the PC using the procedure on P.94.
- \*Do not disconnect the USB cable when the camera is communicating with the PC. See P.94 for information on the disconnection procedure.

## ■ PC Operation

### Windows 98/98 SE/Me/2000 Professional

\* The Windows CD-ROM may also be required during installation. In this event, switch CD-ROMs as directed by the on-screen instructions.

- FinePixViewer automatically starts up.

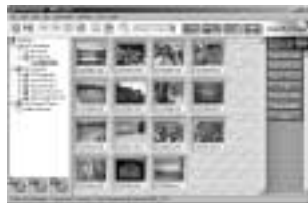

\* Screen for Windows 98 SE

- A removable disk icon appears and you can use your PC to transfer files to and from the camera.



If the above operations do not occur, you do not have the required software programs or drivers installed on your PC. Complete the required PC setup procedures. Then reconnect the camera to your PC.

1. The “Found New Hardware” help message appears in the bottom-right corner of your screen. This message will close when the settings are completed. No action is required.

\* This step is not required for subsequent connections.



2. Specify the settings in the “AutoPlay” dialog box.

### ■ When FinePixViewer is included in the list of actions to perform

Select “Viewing images using FinePixViewer” and then select the “Always do the selected action” checkbox. (This checkbox may not be shown in some cases.)

Click the [OK] button to launch FinePixViewer.

### ■ When FinePixViewer is not included in the list of actions to perform

Select “Take no action” and then select the “Always do the selected action” checkbox. (This checkbox may not be shown in some cases.)

Click the [OK] button and launch FinePixViewer manually.

3. A new removable disk icon appears in the “My Computer” window.

#### TIP

The next time you connect the camera, the removable disk drive icon and name change to the “FinePix” icon and name.



Proceed to “Using FinePixViewer” on page 96.

## 7.3 Use at PC-CAM mode

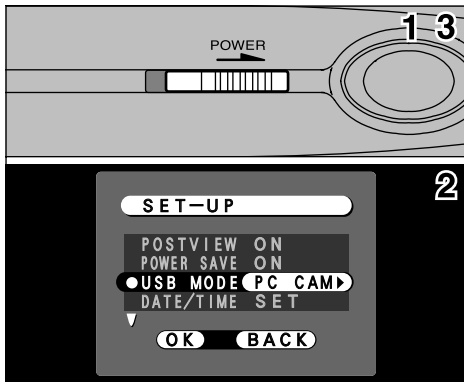

Plug the AC power adapter connector into the DC IN 3V socket on the camera and then plug the adapter itself into the main power outlet.

1. Slide the power switch to the side to turn the camera on.
2. Set the "USB MODE" setting in the "SET-UP" menu to "PC CAM" (⇒P.72, 73).
3. Slide the power switch to the side to turn the camera off.

\*It is recommended that you connect the AC Power Adapter AC-3VH (sold separately) (⇒P.87). Constant

power supply will prevent successful data transfer from trouble caused by power supply.

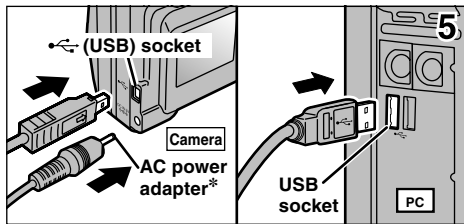

\* Sold separately

4. Switch your PC on.
5. Use the special USB cable to connect the camera to your computer.
6. Switch the camera on.

If you are using a Windows PC, the driver settings are automatically specified when installation ends. Just wait a few moments.

Always use the prescribed procedure when disconnecting or switching off the camera (⇒P.94).

\*Take care to ensure that the special USB cable is connected the correct way around and that the plugs are pushed fully into the connection sockets.

## ■ Camera Operation

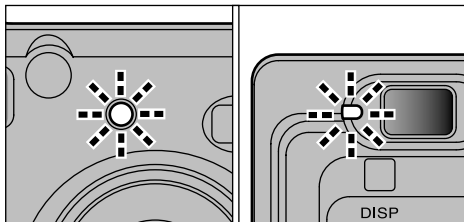

- When the camera and computer are exchanging data, the self timer lamp flashes and the viewfinder lamp flashes alternately green and orange.
- The lens is fixed at the wide-angle zoom setting.
- “PC CAM” appears on the screen.
- Power Save and Auto Power Off are disabled during USB connection.
- \* Do not disconnect the USB cable when the camera is communicating with the PC. See P.94 for information on the disconnection procedure.
- \* If the camera is used as a PC camera, a light source such as fluorescent tube stand can be used to illuminate the subject and get a brighter image.
- \* When the camera is connected to a computer as a PC camera, the color tones on the LCD monitor may change briefly.

## ■ PC Operation

1. FinePixViewer automatically starts up and the PictureHello window opens (Windows only).



\* Screen for Windows 98 SE

If the above operations do not occur, you do not have the required software programs or drivers installed on your PC. Complete the required PC setup procedures. Then reconnect the camera to your PC.

## 2. Check PC operation. The installation procedure differs depending on the operating system running on your PC.

\*This step is not required for subsequent connections.

### Windows 98/98 SE/Me

The “New Hardware Found” wizard appears. The wizard will close when the settings are completed. No action is required.



\* The Windows CD-ROM may also be required during installation. In this event, switch CD-ROMs as directed by the on-screen instructions.

### Windows 2000 Professional

If the “Digital Signature Not Found” dialog box appears, click the [Yes] button.



### Windows XP

The USB PC Camera Driver is installed automatically. When the following screen appears, click the [Continue] button.

## 3. FinePixViewer starts up automatically and the live image is displayed.

### NOTE

If the live image does not appear, refer to “Troubleshooting” in FinePixViewer User’s Guide (PDF).

### TIP

The Exif Launcher installed with the FinePixViewer automatically launches FinePixViewer when you connect the camera to your PC.

## 7.4 Disconnecting the Camera

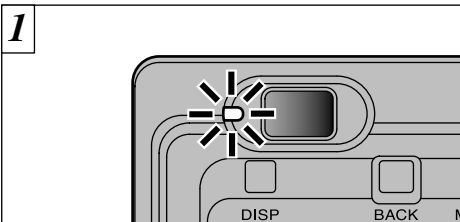

1. Quit all applications (FinePixViewer etc.) that are using the camera.
2. Check that the viewfinder lamp is lit green or that the self timer lamp is off (no data is being exchanged with the computer).

For a DSC connection, proceed to step [2](#).  
For a PC CAMERA connection, proceed to step [3](#).

\*Even when "Copying" is no longer displayed on the computer, the camera and the computer may still be exchanging data. Always check that the viewfinder lamp is lit green or that the self timer lamp is off.

- 2 Perform the steps shown below before you switch the camera off. This procedure differs depending on the operating system software (or PC) you are using.

Windows 98/98 SE

No PC operation is needed.

Windows Me/2000 Professional/XP

1. **Right-click the removable disk icon in the "My Computer" window and select Eject.**  
**This step is only required in Windows Me.**



2. **Left-click the Eject icon in the taskbar and eject "USB Disk".**



\* Screen for Windows Me

3. The menu option shown below appears. Click on this option.



\* Screen for Windows Me

4. The “Eject hardware” dialog box appears. Click the [OK] button or the close button.

Macintosh

Drag the “Removable drive” icon on the desktop to the Trash.



\*When you drag the icon to the Trash, “REMOVE OK” appears on the camera’s LCD monitor.

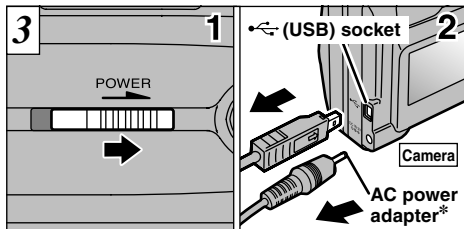

\* Sold separately

1. Switch the camera off.
2. Unplug the special USB cable from the camera.

# 8 Using FinePixViewer

## 8.1 Saving Images on Your Computer and viewing images

This section gives a brief overview of how to use FinePixViewer. Refer to these instructions while you are using FinePixViewer.

1. **Connect the camera to your computer in DSC mode (⇒P.88).**
2. **When you open the folders shown below in order, the images in the camera are displayed in the thumbnail display area.**

### Windows

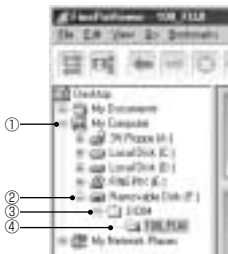

### NOTE

On Windows XP, the removable disk appears as “FinePix” (for the second and subsequent connections).



### Mac OS 8.6-9.2



### Mac OS X



3. **Click the [Automatic Taking] button.**



Copies multiple images at once.

4. Check that the files are downloaded from the camera to your computer and that a folder with the photography date is created. Open the folder as shown below.

**TIP**

To open a folder, click on the plus “+” symbol (Windows) or arrow “▶” (Macintosh) to the left of the folder.

**Windows**

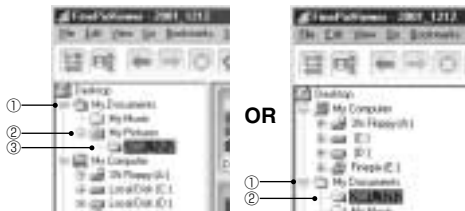

**Mac OS**



Indicates the folder in which FinePixViewer is installed.

5. Double-click a still-image thumbnail to open an image window.

For more information on using the software, refer to “How to use FinePixViewer” in the HELP menu which was installed from the CD-ROM.

Always use the prescribed procedure when disconnecting or switching off the camera (→P.94).

## 8.2 Making a FinePix CD Album

For using “ImageMixer VCD for FinePix” to create CD albums and video CDs.

- To create CD-Rs or video CDs, you will need a CD-R drive.
- Refer to the “ImageMixer VCD for FinePix” help file for more detailed information.
- For inquiries regarding “ImageMixer VCD for FinePix”

### PIXELA User Support Center

PIXELA Home Page: <http://www.ImageMixer.com/>  
North America (Los Angeles) Telephone: +1-213-341-0163  
Europe (U.K.) Telephone: +44-1489-564-764  
Asia (Philippines) Telephone: +63-2-438-0090  
Japan (Osaka) Telephone: +81-72-224-0181

## 8.3 Using the FinePix Internet Service

### NOTE

Mac OS X users should refer to P.100.

Using FinePixViewer also allows you to access the FinePix Internet Service via the Internet.

\* A working Internet connection is required not only for FinePix Internet Service, but also online FAQ (FinePixViewer frequently asked and responses) and latest updates.

\* A FinePix Internet Service fees do not include your Internet service provider (ISP) connection fees or any phone charges incurred in dialing your ISP's access point.

### 8.3.1 Using FAQ

On FinePixViewer, select "QuickStart Guide/Online FAQ" from "Help" menu, then click "FinePixViewer Q&A". You may obtain an answer to your question via internet.

### 8.3.2 User Registration

#### ■ For Windows and Mac OS 8.6 to 9.2

### NOTE

Your user ID and password are very important. Make sure you do not forget them.

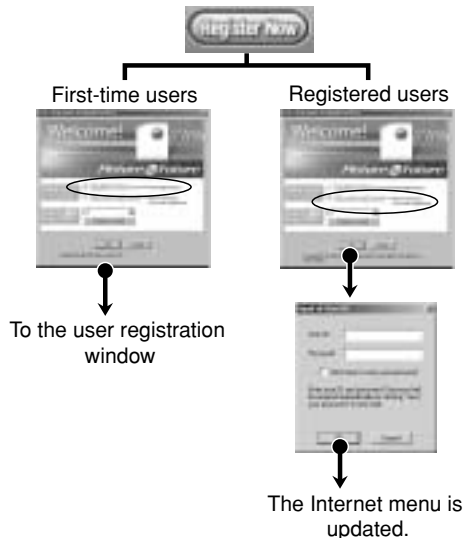

To use the FinePix Internet services, users must first register.

\* Follow the steps below to register. Users can be registered for free.

**1. Launch FinePixViewer.**

**2. Click the [Register Now] button.**



**3. The “User’s Registration for Internet Services” dialog box opens. As shown at right, select [Register Here], then select the country or region where you are living and click the [OK] button.**

\* If you are not already connected to the Internet, connect now (A dial-up dialog box may be displayed).

\* If you have completed the user registration, select “Already Registered” (E.g. When you want to re-install FinePixViewer after completing user registration).

\* If the country or area where you are living does not appear in the pull-down list, select “OTHERS”.



**4. When the browser starts up, proceed as directed by the on-screen instructions.**

**5. Enter the required information in the user registration page.**



- ① Enter the name of your choice (nickname, etc.).
- ② Enter a password of your choice using letters and/or numbers. Then enter the password again for confirmation.
- ③ Enter your name.
- ④ Enter your E-mail address.
- ⑤ Enter the remaining required information.

\* After you register, a confirmation E-mail message is sent to you. Be sure to enter a valid E-mail address at which you can receive the message.

\* The actual user registration page may differ slightly in appearance from the sample shown here.

**6. When you have entered all the required information, click the [Registration] button at the bottom of the page.**

Once you complete the registration, a confirmation E-mail is sent. Wait a few moments until the message is sent.

**■ For Mac OS X**

To use the FinePix Internet services, users must first register.

\* Follow the steps below to register. Users can be registered for free.

- 1. Double-click the “FinePixViewer” icon in the installed folder.**
- 2. Click the [User’s Registration] button. The “Operation Selection” dialog box appears.**



<User's Registration button>



**3. Select “User’s registration” and click the [OK] button.**

- \* If you are not already connected to the Internet, connect now. (A dial-up dialog box may be displayed.)
- \* Only select menu acquisition if you have already completed the user registration process and you have re-installed “FinePixViewer”, etc.



**4. The User’s Registration dialog box opens. Select the country or area where you are living and click the [OK] button.**



- \* The actual user registration page may differ slightly in appearance from the sample shown here.
- \* If the country or area where you are living does not appear in the pull-down list, select “OTHERS”.

**5. When the browser starts up, proceed as directed by the on-screen instructions.**

**6. Enter the required information in the user registration page.**



- ① Enter the name of your choice (nickname, etc.).
- ② Enter a password of your choice using letters and/or numbers. Then enter the password again for confirmation.
- ③ Enter your name.
- ④ Enter your E-mail address.
- ⑤ Enter the remaining required information.

- \* After you register, a confirmation E-mail message is sent to you. Be sure to enter a valid E-mail address at which you can receive the message.
- \* The actual user registration page may differ slightly in appearance from the sample shown here.

**7. When you have entered all the required information, click the [Register] button at the bottom of the page.**

Once you complete the registration, a confirmation E-mail is sent. Wait a few moments until the message is sent.

## 8.4 Mastering FinePixViewer

For more information on FinePixViewer functions not fully explained in this manual, refer to **“How to Use FinePixViewer”** in the Help menu for details.

### ■ To read **“How to Use FinePixViewer”**...

You must install Adobe Systems' Acrobat Reader. See P.75 for information on installing Acrobat Reader.

### ■ What is explained in **“How to Use FinePixViewer”**...

“How to Use FinePixViewer” covers a range of topics, including batch processing and ordering prints.

### ■ Example: Looking up slide shows

1. Click **“How to Use FinePixViewer”** in the FinePixViewer Help menu.
2. Search for relevant articles by clicking the corresponding items in the Help **“Bookmarks”** or **“Contents”**. Here, click **“Viewing Slide Shows”**.

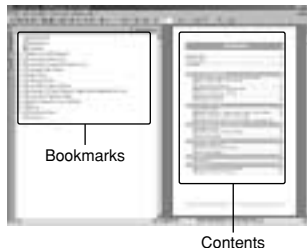

3. The **“Viewing Slide Shows”** information is displayed. Press the **“←”** key to view the previous page or the **“→”** key to view the next page.



\* For more information on using Acrobat Reader, refer to the Acrobat Reader **“Help”** menu.

## 8.5 Uninstalling the Software

Only perform this operation when you no longer require the installed software or when the software was not installed correctly.

### Windows

1. Switch on your PC.
2. Disconnect the camera (⇒P.94, 95).
3. Quit all currently running applications.
4. Close all files.
5. Open the “My Computer” window, open the “Control Panel”, and double-click “Add/Remove Programs”.



6. The “Add/Remove Programs Properties” window appears. Select the software to be uninstalled (FinePixViewer or the driver) and then click the [Add/Remove] button.

<To remove FinePixViewer>

FinePixViewer Ver.3.2

<To remove the driver software>

FUJIFILM USB Driver



7. When the confirmation message appears, click the [OK] button. Check your selection carefully since the process cannot be cancelled once you click [OK].



8. Automatic uninstallation begins. When uninstallation ends, click the [OK] button.

**NOTE**

Only perform this operation when you no longer require the installed software or when the software was not installed correctly.

■ **Uninstalling Mass Storage Driver and PC Camera Driver**

1. Check that the camera is not connected to your Macintosh.
2. Drag all the files that begin with “USB04CB...” to the Trash.
3. Restart your Macintosh.
4. Select “Empty Trash” in the “Special” menu.

■ **Uninstalling Exif Launcher, FinePixViewer and DP Editor**

1. After you have quit Exif Launcher in “Exif Launcher Settings” in the FinePixViewer “Settings” menu, move the Exif Launcher file from the “Startup Items” folder in the System folder to the Trash. Then select “Empty Trash” in the “Special” menu.
2. After you have exited FinePixViewer and DP Editor and then drag the installed

FinePixViewer folder to the Trash. Then click “Empty Trash” in the “Special” menu.

■ **Uninstalling FinePixViewer**

Quit FinePixViewer and DP Editor. Then drag the installed FinePixViewer folder to the Trash and select “Empty Trash” in the “Special” menu.

# System Expansion Options

- By using the FinePix A203/FinePix A303 together with other optional FUJIFILM products, your system can be expanded to fill a wide range of uses.

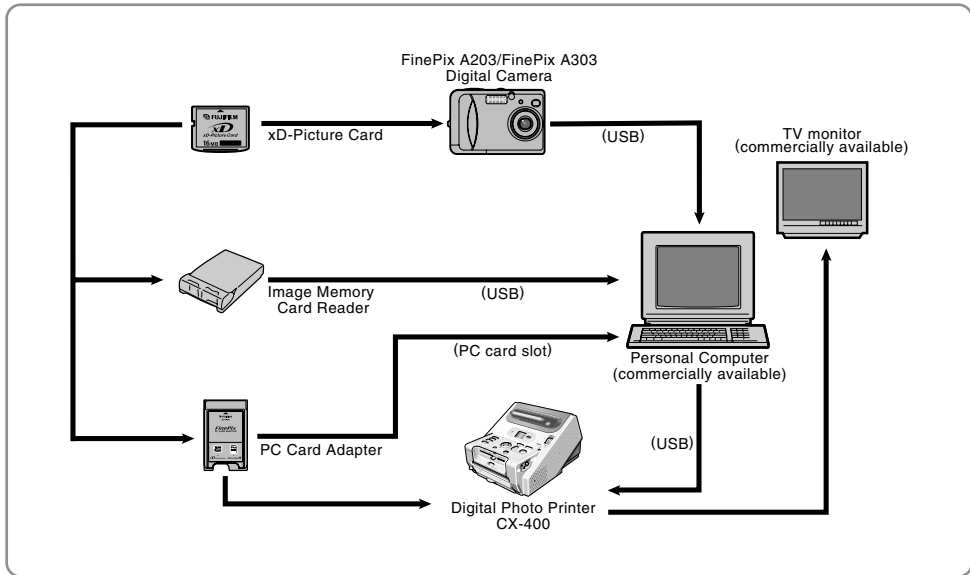

# Accessories Guide

- The optional accessories (sold separately) can make taking pictures with the FinePix A203/FinePix A303 even easier. For information on how to attach and use the accessories, refer to the instructions provided with the accessory used.

Visit the FUJIFILM web site for the latest information on camera accessories.

<http://home.fujifilm.com/products/digital/index.html>

## ● xD-Picture Card

These are separately available xD-Picture Card cards.

Use the following xD-Picture Card:

DPC-16 (16MB)/DPC-32 (32MB)/DPC-64 (64MB)/DPC-128 (128MB)



## ● AC Power Adapter AC-3V

Use the AC power adapter when you want to take pictures or play back images for long periods or when the camera is connected to a computer.

\* The shape of the AC power adapter, the plug and socket outlet depend on the country.

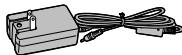

## ● Fujifilm Rechargeable Battery 2HR-3UF

The 2HR-3UF includes 2 pieces of high-capacity AA-size Nickel-Metal Hydride (Ni-MH) batteries.

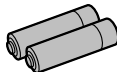

## ● Fujifilm Battery charger with Battery BK-NH (With Euro type or UK type plug)

The BK-NH includes the quick battery charger BCH-NH and 2 Ni-MH batteries.

The BCH-NH can charge 2 Ni-MH batteries in approximately 120 minutes.

Up to 4 Ni-MH batteries can be charged simultaneously.

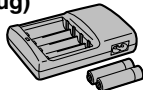

---

● **SC-FXA01**

This is a special case made of polyester that protects the camera against soil, dust and minor impacts when it is being carried.

● **DPC-R1 Image Memory Card Reader**

The DPC-R1 provides a quick and easy way to transfer images back and forth between your PC and an image memory card (xD-Picture Card and SmartMedia). The DPC-R1 uses the USB interface for high-speed file transfer.

- Compatible with Windows 98/98 SE, Windows Me, Windows 2000 Professional, Windows XP or iMac, Mac OS 8.6 to 9.2, Mac OS X (10.1.2 to 10.1.5) and models that support USB as standard.
- Compatible with SmartMedia of 3.3V, 4MB to 128MB.

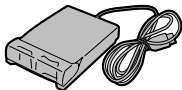

● **DPC-AD PC Card Adapter**

The PC Card Adapter allows the xD-Picture Card and SmartMedia to be used as a PC Card Standard ATA-compliant (PCMCIA 2.1) PC card (Type II).

- Compatible with SmartMedia of 3.3V, 2MB to 128MB.



# Notes on Using Your Camera Correctly

---

► Be sure to read this information in conjunction with “Safety Notes” (➔P.125), to ensure that you use your camera correctly.

## ■ Places to Avoid

Do not store or use the camera in the following types of locations:

- In the rain or in very humid, dirty or dusty places.
- In direct sunlight or in places subject to extreme temperature rises, such as in a closed car in summer.
- Extremely cold places.
- Places subject to strong vibration.
- Places affected by smoke or steam.
- Places subject to strong magnetic fields (such as near motors, transformers or magnets).
- In contact with chemicals such as pesticides or next to rubber or vinyl products for long periods of time.

## ■ Notes on Immersion in Water or Sand

The FinePix A203/FinePix A303 is particularly adversely affected by water and sand. When you are at the beach or close to water, ensure that the camera is not exposed to water or sand. Take care not to place the camera on a wet surface. Water or sand inside the camera can cause faults that may be irreparable.

## ■ Notes on Condensation

If the camera is carried suddenly from a cold location into a warm place, water droplets (condensation) may form on the inside of the camera or on the lens. When this occurs, switch the camera off and wait an hour before using the camera. Condensation may also form on the xD-Picture

card. In this event, remove the xD-Picture Card and wait a short time before using it again.

## ■ When the Camera is Unused for Long Periods

If you do not intend to use the camera for a long period of time, remove the battery and the xD-Picture Card card before storing the camera.

## ■ Cleaning Your Camera

- Use a blower brush to remove dust from the lens, LCD monitor screen or viewfinder, and then wipe lightly with a soft, dry cloth. If any soil remains, apply a small amount of lens cleaning liquid to a piece of FUJIFILM lens cleaning paper and wipe gently.
- Do not scratch hard objects against the lens, LCD monitor screen or viewfinder as these surfaces are easily damaged.
- Clean the body of the camera with a soft, dry cloth. Do not use volatile substances such as thinners, benzine or insecticide, as these may react with camera body and cause deformation or remove the coating.

## ■ Using the Camera Overseas

When travelling overseas, do not place your camera in the check-in baggage. Baggage handling at airports may subject baggage to violent shocks, and the camera may be damaged internally even when no external damage is visible.

# Notes on the Power Supply

---

## Applicable Batteries

- AA-size alkaline, Ni-MH (nickel-metal hydride) can be used with this camera.  
Do not use AA-size manganese, lithium or nickel-cadmium (Ni-Cd) batteries in your FinePix A203/ FinePix A303 because the heat generated by the batteries could damage the camera or cause malfunctions.
- The operating lives of alkaline batteries vary between brands and the life of batteries you purchase may be shorter than the alkaline batteries provided with the camera.

## Notes on the Batteries

Incorrect use of the batteries could cause them to leak, become hot, ignite or burst. Always observe the precautions given below.

- Do not heat the batteries or throw them into a fire.
- Do not carry or store a battery with metal objects such as necklaces or hairpins that could come into contact with the metal positive ⊕ and negative ⊖ poles of the battery.
- Do not expose the batteries to fresh or sea water, and take particular care to keep the terminals dry.
- Do not attempt to deform, disassemble or modify the batteries.
- Do not attempt to peel off or cut the battery casing.
- Do not drop, strike or otherwise subject the batteries to strong impacts.

- Do not use batteries that are leaking, deformed, discolored or exhibit any other obvious abnormality.
- Do not store batteries in very warm or moist locations.
- Keep the batteries out of reach of babies and small children.
- When loading the batteries into the camera, ensure that the battery polarity (⊕ and ⊖) is as indicated on the camera.
- Do not use new batteries together with used batteries. In the case of rechargeable batteries, do not use charged and discharged batteries together. Do not use batteries of different types or brands together.
- If you do not intend to use the camera for a long period of time, remove the batteries from the camera. (Note that if the camera is left with the batteries removed, the time and date settings are cleared.)
- The batteries may feel warm immediately after being used. Before removing the batteries, switch the camera off and wait until the batteries cool down.
- When replacing the batteries, always fit 2 new batteries. Here, 'new batteries' refers to either recently purchased unused alkaline batteries, or Ni-MH (nickel metal hydride) batteries that have recently been fully recharged together.
- In cold locations (at temperatures of +10°C/+50°F or below), battery performance deteriorates and the time for which they can be used shortens markedly. This is particularly true of alkaline batteries. In cold conditions,

# Notes on the Power Supply

---

put the batteries in your pocket or a similar place to warm them before loading them into the camera. If you use a body warmer to warm the batteries, ensure that they are not in direct contact with the warmer.

- Soil (such as fingerprints) on the battery terminals can markedly reduce the number of available shots. Carefully wipe the battery terminals clean with a soft dry cloth before loading the batteries.

⚠ If any liquid at all leaks from the batteries, wipe the battery compartment thoroughly and then load new batteries.

⚠ If any battery fluid comes into contact with your hands or clothing, flush the area thoroughly with water. Note that battery fluid can cause loss of eyesight if it gets into your eyes. If this occurs, do not rub your eyes. Flush the fluid out with clean water and contact your physician for treatment.

## ■ Disposing of Batteries

When disposing of batteries, do so in accordance with your local waste disposal regulations.

## ■ Notes on Small Rechargeable Batteries (Ni-MH batteries)

- Always use the special battery charger to charge AA-size Ni-MH batteries. Charge the batteries as described in the instructions provided with the battery charger.

- Do not use the battery charger to charge batteries other than those specified for use with the charger.
- Note that the batteries may feel warm immediately after being charged.
- Ni-MH batteries are not charged at shipment. Be sure to charge the batteries before using them.
- The camera mechanism is such that it draws a minute amount of current even when the camera is switched off. Take particular care not to leave Ni-MH batteries in the camera for a long period of time as they can become excessively discharged and may no longer be usable even when charged.
- Ni-MH batteries self-discharge even when not used. Always charge Ni-MH batteries before using them. If the time for which a battery provides power shortens markedly when it has been correctly charged, this indicates that the battery has reached the end of its effective life and should be replaced.
- Soil (fingerprints, etc) on the terminals of Ni-MH batteries can greatly reduce the number of available shots. When this occurs, clean the terminals carefully with a soft dry cloth. Then use up the remaining charge in the batteries and recharge them.
- Newly purchased batteries or batteries that have been left unused for an extended period may not be fully charged (This is indicated by the immediate display of the battery low warning or a low number of available shots). This is a normal characteristic of the batteries and does not indicate a fault. Repeatedly charging and using the batteries 3 times or 4 times

---

will restore them to a normal condition.

- If you repeatedly charge a Ni-MH battery before it is fully discharged, it will suffer from the “memory effect”\*, causing the battery low warning to appear while there is still ample charge remaining in the battery. To restore the batteries to their normal condition, use up all the charge in the batteries before recharging them.

\* Memory effect: A phenomenon affecting the battery characteristics such that the apparent battery capacity decreases.

## AC Power Adapter

Use only the AC-3V AC Power Adapter with your FinePix A203/FinePix A303 Digital Camera. The use of other AC power adapters may result in damage to your camera.

- This AC power adapter is designed exclusively for indoor use.
- Plug the connection cord plug securely into the DC input terminal of the FUJIFILM Digital camera.
- Turn off the power switch of the FUJIFILM Digital camera before disconnecting the connection cord from the FUJIFILM Digital camera’s DC input terminal. To disconnect, take hold of the plug and pull it out (do not disconnect it by pulling on the cord).
- Do not use this AC power adapter with any device except the specified device.
- During use, this AC power adapter will become hot to the

touch, but this is normal.

- Do not disassemble the AC power adapter. Doing so could be dangerous.
- Do not use this device in a place with high temperature and high humidity.
- Do not drop or subject this device to strong shocks.
- This device may emit a humming noise, but this is normal.
- If used near a radio, this device may cause static, so play the radio in a distant place.

# Notes on the xD-Picture Card

---

## ■ Image Memory Card

- This Image Memory Card is a new image recording media (xD-Picture Card) developed for digital cameras. The Image Memory Card consists of a semiconductor memory (NAND-type flash memory) to record digital image data.

The recording process is electrically performed and enables erasure of existing image data as well as re-recording of new image data.

- When using a new Memory Card, or a Memory Card that has been initialized by a PC, be sure to initialize (format/initialize) the card with your digital camera before using it.

## ■ Protecting Your Data

- Data may be lost or destroyed in the following situations. Please note that FUJIFILM assumes no responsibility for data that is lost or destroyed.
  1. Removal of the memory card or turning the power off while the memory card is being accessed (i.e., during record, erase, initialization, and playback operations).
  2. Improper handling and use of the memory card by the user or third party.
- We recommend saving your important data to another media (i.e., MO disk, CD-R, hard disk, etc.).

## ■ Notes on Handling xD-Picture Card

- Keep xD-Picture Cards out of the reach of small

children. When storing xD-Picture Cards, ensure that they are kept in a location out of the reach of small children to prevent a card being accidentally swallowed. An xD-Picture Card could cause suffocation if accidentally swallowed. If a child swallows an xD-Picture Card, seek medical advice immediately.

- Make sure that the memory card is straight when you insert into the camera etc.
- The memory card is a precision electronic instrument. Do not apply pressure or shock, and avoid bending.
- Do not use the memory card in a hot, humid, or corrosive environment.
- If the contact area on the card is soiled (dust, fingerprints, etc.), wipe it clean with a soft, dry cloth.
- Clean the memory card with a soft dry piece of cloth when dirty.
- When you carry or store it, always keep the card in the anti-static case provided. Use a storage case if available.
- The memory card can be used reliably for a long period of time, but will eventually lose its ability to store and play back image data. At this point, replace with a new memory card.
- Never remove the xD-Picture Card or switch the camera off during data recording, during data erasing (xD-Picture Card formatting) or during frame advance when images are being played back. These actions

---

could result in damage to the xD-Picture Card.

- The use of xD-Picture Cards is recommended with the FinePix A203/FinePix A303.

The camera quality cannot be guaranteed when cards other than those manufactured by FUJIFILM are used.

- The xD-Picture Card may feel warm when it is removed from the camera after extended periods of picture taking or image viewing. This is normal and does not indicate a fault.
- Do not affix labels to the xD-Picture Card. This could result in the label peeling off and causing a fault when the card is inserted or removed.

### ■ Notes on Using xD-Picture Cards with a PC

- If you intend to take photos using an xD-Picture Card that has been used on a PC, format the xD-Picture Card on your camera.
- When you format an xD-Picture Card in the camera and then shoot and record images, a directory (folder) is automatically created. Image data is then recorded in this directory.
- Do not change or delete the directory (folder) names or file names on the xD-Picture Card from your PC as this will make it impossible to use the xD-Picture Card in your camera.
- Always use the camera to erase image data on an xD-Picture Card.
- To edit image data, copy the image data to the PC's

hard disk and then edit the copied data.







- Do not copy files other than those that will be used by the camera.





### ■ Specifications

Type	Image memory card for digital cameras (xD-Picture Card)
Memory type	NAND-type flash memory
Conditions for use	Temperature: 0°C to +40°C (+32°F to +104°F) Humidity: 80% max. (no condensation)
Dimensions	25 mm × 2.2 mm × 20 mm (0.98 in. × 0.09 in. × 0.79 in.) (W × H × D)

# Warning Displays

► The table below lists the warnings that are displayed on the LCD monitor.

Warning Displayed	Explanation	Remedy
 (Lit red)  (Blinking red)	The batteries in the camera are fully depleted or very low on charge.	Replace the batteries or have new batteries ready.
	No xD-Picture Card is loaded.	Load a xD-Picture Card.
	<ul style="list-style-type: none"><li>• The xD-Picture Card is not formatted.</li><li>• The xD-Picture Card contact area is soiled.</li><li>• Camera fault.</li></ul>	<ul style="list-style-type: none"><li>• Wipe the contact area on the xD-Picture Card with a soft dry cloth. It may be necessary to format the xD-Picture Card. If the error message is still displayed, replace the xD-Picture Card.</li><li>• Contact your FUJIFILM dealer.</li></ul>
	<ul style="list-style-type: none"><li>• The xD-Picture Card contact area is soiled.</li><li>• The xD-Picture Card is damaged.</li><li>• The xD-Picture Card format is incorrect.</li><li>• Camera fault.</li></ul>	<ul style="list-style-type: none"><li>• Wipe the contact area on the xD-Picture Card with a soft dry cloth. It may be necessary to format the xD-Picture Card. If the error message is still displayed, replace the xD-Picture Card.</li><li>• Contact your FUJIFILM dealer.</li></ul>
	The xD-Picture Card is fully recorded.	Erase some images or use a xD-Picture Card that has ample free space.

Warning Displayed	Explanation	Remedy
	<ul style="list-style-type: none"> <li>• An attempt was made to playback a frame not recorded on this camera.</li> <li>• The xD-Picture Card contact area is soiled.</li> <li>• You attempted to play back a movie file that was not recorded on this camera.</li> </ul>	<ul style="list-style-type: none"> <li>• Images cannot be played back.</li> <li>• Wipe the contact surface on the xD-Picture Card thoroughly with a soft, dry cloth. In some cases, you may have to format the xD-Picture Card.</li> <li>• Play back the movie on a computer or on the camera on which it was recorded.</li> </ul>
	<p>The playback frame number has reached 999–9999.</p>	<p>Take the shots using a formatted xD-Picture Card.</p>
	<ul style="list-style-type: none"> <li>• The data could not be recorded due to a xD-Picture Card error or a connection error between the xD-Picture Card and camera.</li> <li>• The photographed image cannot be recorded because the xD-Picture Card is full.</li> </ul>	<ul style="list-style-type: none"> <li>• Reload the xD-Picture Card or switch the camera off and then on again.</li> <li>• Use a new xD-Picture Card.</li> </ul>
	<p>There is a strong likelihood of camera shake because the shutter speed is slow.</p>	<p>Use flash photography. However, a tripod should be used for some scenes and modes.</p>

## Warning Displays

Warning Displayed	Explanation	Remedy
<b>! PROTECTED FRAME</b>	A protected frame was encountered.	Protected files cannot be erased. Unprotect the image.
<b>! AE</b>	Outside the AE (Auto-exposure) continuous range.	The shot can be taken, but the exposure will not be correct.
<b>! AF</b>	The AF (Autofocus) cannot work effectively.	<ul style="list-style-type: none"><li>• If the image is too dark, take the picture at a distance of around 2 m (6.6 ft.) from the subject.</li><li>• Use AF lock to take the picture.</li></ul>
<b>! DPOF FILE ERROR</b>	Prints were specified for more than 1000 frames in the DPOF frame settings.	The maximum number of frames for which prints can be specified on the same xD-Picture Card is 999.
<b>! FOCUS ERROR</b> <b>! ZOOM ERROR</b> <b>! LENS COVER</b>	Camera malfunction or fault.	<ul style="list-style-type: none"><li>• Switch the camera on again, taking care not to touch the lens.</li><li>• Turn the camera off and on again a few times.</li></ul>

# Troubleshooting

► If you think the camera is faulty, check the following once more

Problem	Cause	Remedy
No power.	<ul style="list-style-type: none"><li>• The battery is exhausted.</li><li>• The AC power adapter plug has come out of the power outlet.</li></ul>	<ul style="list-style-type: none"><li>• Replace the batteries.</li><li>• Plug the adapter back in.</li></ul>
Power cuts out during operation.	<ul style="list-style-type: none"><li>• The battery is exhausted.</li></ul>	<ul style="list-style-type: none"><li>• Replace the batteries.</li></ul>
Battery runs out quickly.	<ul style="list-style-type: none"><li>• You are using the camera in extremely cold conditions.</li><li>• The terminals are soiled.</li><li>• The battery is flat.</li></ul>	<ul style="list-style-type: none"><li>• Put the battery in your pocket or another warm place to heat it and then load it into the camera just before you take a picture.</li><li>• Wipe the battery terminals with a clean, dry cloth.</li><li>• Purchase new batteries.</li></ul>
No photograph is taken when the shutter button is pressed.	<ul style="list-style-type: none"><li>• No xD-Picture Card is loaded.</li><li>• The xD-Picture Card is fully recorded.</li><li>• The xD-Picture Card is not formatted.</li><li>• The xD-Picture Card contact area is soiled.</li><li>• The xD-Picture Card is damaged.</li><li>• The camera has been switched off because 2 minutes have elapsed since it was last used.</li><li>• The battery is exhausted.</li></ul>	<ul style="list-style-type: none"><li>• Load a xD-Picture Card.</li><li>• Insert a new xD-Picture Card or erase some unwanted frames.</li><li>• Format the xD-Picture Card.</li><li>• Wipe the xD-Picture Card contact area with a clean, dry cloth.</li><li>• Load a new xD-Picture Card.</li><li>• Switch the camera on.</li><li>• Purchase new batteries.</li></ul>

## Troubleshooting

► If you think the camera is faulty, check the following once more

Problem	Cause	Remedy
Can't use the flash to take pictures.	<ul style="list-style-type: none"><li>• The flash is set to Suppressed Flash mode.</li><li>• You pressed the shutter button while the flash was charging.</li><li>• The battery is exhausted.</li></ul>	<ul style="list-style-type: none"><li>• Set the flash to Auto, Red-Eye Reduction or Forced Flash mode.</li><li>• Wait until charging is completed before pressing the shutter button.</li><li>• Replace with new batteries.</li></ul>
The playback image is too dark even though the flash was used.	<ul style="list-style-type: none"><li>• The subject is too far away.</li><li>• Your fingers are obscuring the flash or flash control sensor.</li></ul>	<ul style="list-style-type: none"><li>• Move closer to the subject.</li><li>• Hold the camera correctly.</li></ul>
The image is blurred.	<ul style="list-style-type: none"><li>• The lens is dirty.</li><li>• The photographed subject was too dark.</li></ul>	<ul style="list-style-type: none"><li>• Clean the lens.</li><li>• Try standing approx. 2 m (6.6 ft.) from your subject to take the picture.</li></ul>
There is speckling on the image.	<ul style="list-style-type: none"><li>• The shot was taken with a slow shutter speed (long exposure) in a high-temperature environment.</li></ul>	<ul style="list-style-type: none"><li>• This is a characteristic of CCDs and does not indicate a camera fault.</li></ul>
Can't format the xD-Picture Card.	<ul style="list-style-type: none"><li>• The xD-Picture Card contact area is soiled.</li></ul>	<ul style="list-style-type: none"><li>• Wipe the xD-Picture Card contact area with a clean dry cloth.</li></ul>

Problem	Cause	Remedy
<p>The ERASE ALL function does not erase all the frames.</p> <p>Frame erase does not erase the frame.</p>	<ul style="list-style-type: none"> <li>• Some frames may be protected.</li> </ul>	<ul style="list-style-type: none"> <li>• Unprotect frames using the camera on which the protection was first applied.</li> </ul>
<p>Nothing happens when I use the Mode dial.</p>	<ul style="list-style-type: none"> <li>• Camera malfunction.</li> <li>• The batteries exhausted.</li> </ul>	<ul style="list-style-type: none"> <li>• Briefly remove the batteries or disconnect the AC power adapter. Then reload the batteries or reconnect the AC power adapter and try again.</li> <li>• Replace with new batteries.</li> </ul>
<p>When the camera is connected to a personal computer (PC), the shot image appears on the camera's LCD monitor.</p>	<ul style="list-style-type: none"> <li>• The special USB cable is not connected correctly to the PC or camera.</li> <li>• The PC is not switched on.</li> </ul>	<ul style="list-style-type: none"> <li>• Set up the camera and USB cable correctly.</li> <li>• Switch the PC on.</li> </ul>
<p>The camera no longer works correctly.</p>	<ul style="list-style-type: none"> <li>• The camera has suffered an unforeseen problem.</li> </ul>	<ul style="list-style-type: none"> <li>• Remove the batteries briefly and then reload the batteries and try again.</li> </ul>

# Specifications (FinePix A203)

## System

- **Model:** Digital Camera FinePix A203
- **Number of effective pixels:** 2.0 million pixels
- **CCD sensor**  
1/2.7-inch square pixel CCD with RGB Filter  
Number of total pixels: 2.11 million pixels
- **Number of recorded pixels**  
1600 × 1200 pixels (1.92 million pixels)/  
1280 × 960 pixels/640 × 480 pixels
- **Storage media**  
xD-Picture Card (16MB to 128MB)
- **File format**  
Still image: JPEG (Exif Ver. 2.2), DPOF-compatible  
Movie: AVI format, Motion JPEG  
\*Design rule for Camera File system Compliant
- **Viewfinder**  
Real image optical; Frame coverage: 80%
- **Lens**  
Fujinon 3× optical zoom lens  
f=38-114 mm on a 35 mm camera
- **Aperture**  
F2.8-F4.8/F7.0-F11.6 (automatically selected)
- **Focus distance**  
f=5.7-17.1 mm (equivalent to 38 mm on a 114mm camera)
- **Exposure control**  
64 zones TTL metering, Program AE  
(exposure compensation available in Manual mode)
- **Sensitivity**  
Equivalent to ISO 100
- **White balance**  
Auto (7 positions selectable in Manual mode)
- **Focal range**  
Normal: Approx. 60 cm/2.0 ft. to infinity  
Macro: Approx. 10 cm-80 cm/3.9 in.-2.6 ft.
- **Shutter speeds**  
Variable-speed, 1/2 sec. to 1/2000 sec. (combined with mechanical shutter)
- **Flash (Auto flash using flash control sensor)**  
Effective range:  
Wide-angle: Approx. 30 cm-3.5 m (1.0 ft. -11.5 ft.)  
Telephoto-angle: Approx. 60 cm-3.0 m (2.0 ft. -9.8 ft.)  
Flash modes: Auto, Red-Eye Reduction, Forced Flash, Suppressed Flash, Slow Synchro

## ■ Standard number of available shots/recording time per xD-Picture Card

Quality Mode	2M • F	2M • N	1M	0.3M	320 (Movie)	160 (Movie)
Number of recorded pixels	1600 × 1200		1280 × 960	640 × 480	320 × 240	160 × 120
Image Data Size	Approx. 620 KB	Approx. 390 KB	Approx. 320 KB	Approx. 130 KB	—	—
DPC-16 (16 MB)	25	39	49	122	Approx. 94 sec.	Approx. 5 min.
DPC-32 (32 MB)	50	79	99	247	Approx. 191 sec.	Approx. 10.1 min.
DPC-64 (64 MB)	101	159	198	497	Approx. 6.4 min.	Approx. 20.2 min.
DPC-128 (128 MB)	204	319	398	997	Approx. 12.9 min.	Approx. 40.6 min.

- **LCD monitor**

1.5-inches, 60,000-pixels TFT

- **Self-Timer**

10 sec. timer clock

## Input/Output Terminals

-  (USB) socket

USB (1) for image data output with a personal computer

- **DC IN 3V (Power input) socket**

Socket for specified AC power adapter (optional)

## Power Supply and Others

- **Power supply**

Use one of the following:

- 2AA-size alkaline batteries
- 2AA-size Ni-MH (nickel-metal hydride) batteries (optional)
- AC Power Adapter AC-3V (optional)

- **No. of available shots using battery (battery life)**

Battery type	With LCD monitor ON	With LCD monitor OFF
Alkaline batteries	Approx. 200 frames	Approx. 300 frames
Ni-MH batteries HR-3UF 1700 mAh	Approx. 300 frames*	Approx. 400 frames*

(Condition: Power saving mode ON, with fully charged battery (Ni-MH))

This indicates the number of available frames shot consecutively at room temperature with a flash use rate of 50%. Note that these figures may vary depending on the ambient temperature and the amount of charge in the battery. The number of available shots or available shooting time will be lower in cold conditions.

- **Conditions for use**

Temperature: 0°C to +40°C (+32°F to +104°F); 80% humidity or less (no condensation)

- **Camera dimensions (W/H/D)**

97.0 mm × 63.9 mm × 34.3 mm/3.8 in. × 2.5 in. × 1.4 in. (not including accessories and attachments)

- **Camera mass (weight)**

Approx. 145 g/5.1 oz. (not including accessories, batteries or xD-Picture Card)

- **Weight for photography**

Approx. 200 g/7.1 oz. (including batteries and xD-Picture Card)

- **Accessories**

See P.7

- **Optional Accessories**

See P.106, 107

\* These specifications are subject to change without notice. FUJIFILM shall not be held liable for damages resulting from errors in this Owner's Manual.

\* The LCD monitor on your digital camera is manufactured using advanced high-precision technology. Even so, small bright points and anomalous colors (particularly around text) may appear on the monitor. These are normal display characteristics and do not indicate a fault with the monitor. This phenomenon will not appear on the recorded image.

\* The operation error may be caused in a digital camera by the strong radio interference (i. e. electric fields, static electricity, line noise, etc.).

\* Due to the nature of the lens, the edges of photographed images may appear distorted. This is normal and does not indicate a fault.

# Specifications (FinePix A303)

## System

- **Model:** Digital Camera FinePix A303
- **Number of effective pixels:** 3.24 million pixels
- **CCD sensor**  
1/2.7-inch square pixel CCD with RGB Filter  
Number of total pixels: 3.34 million pixels
- **Number of recorded pixels**  
2048 × 1536 pixels (3.15 million pixels)/  
1600 × 1200 pixels/1280 × 960 pixels/640 × 480 pixels
- **Storage media**  
xD-Picture Card (16MB to 128MB)
- **File format**  
Still image: JPEG (Exif Ver. 2.2), DPOF-compatible  
Movie: AVI format, Motion JPEG  
\*Design rule for Camera File system Compliant
- **Viewfinder**  
Real image optical; Frame coverage: 80%
- **Lens**  
Fujinon 3× optical zoom lens  
f=35-114 mm on a 35 mm camera

- **Aperture**  
F2.8-F4.8/F7.0-F11.6 (automatically selected)
- **Focus distance**  
f=5.7-17.1 mm (equivalent to 38 mm on a 114mm camera)
- **Exposure control**  
64 zones TTL metering, Program AE  
(exposure compensation available in Manual mode)
- **Sensitivity**  
Equivalent to ISO 100
- **White balance**  
Auto (7 positions selectable in Manual mode)
- **Focal range**  
Normal: Approx. 60 cm/2.0 ft. to infinity  
Macro: Approx. 10 cm-80 cm/3.9 in.-2.6 ft.
- **Shutter speeds**  
Variable-speed, 1/2 sec. to 1/2000 sec. (combined with mechanical shutter)
- **Flash (Auto flash using flash control sensor)**  
Effective range:  
Wide-angle: Approx. 30 cm-3.5 m (1.0 ft. -11.5 ft.)  
Telephoto-angle: Approx. 60 cm-3.0 m (2.0 ft. -9.8 ft.)  
Flash modes: Auto, Red-Eye Reduction, Forced Flash, Suppressed Flash, Slow Synchro

## ■ Standard number of available shots/recording time per xD-Picture Card

Quality Mode	3M • F	3M • N	2M	1M	0.3M	320 (Movie)	160 (Movie)
Number of recorded pixels	2048 × 1536		1600 × 1200	1280 × 960	640 × 480	320 × 240	160 × 120
Image Data Size	Approx. 1300 KB	Approx. 590 KB	Approx. 390 KB	Approx. 320 KB	Approx. 130 KB	—	—
DPC-16 (16 MB)	12	26	39	49	122	Approx. 94 sec.	Approx. 5 min.
DPC-32 (32 MB)	25	53	79	99	247	Approx. 191 sec.	Approx. 10.1 min.
DPC-64 (64 MB)	50	107	159	198	497	Approx. 6.4 min.	Approx. 20.2 min.
DPC-128 (128 MB)	102	215	319	398	997	Approx. 12.9 min.	Approx. 40.6 min.

- **LCD monitor**

1.5-inches, 60,000-pixels TFT

- **Self-Timer**

10 sec. timer clock

## Input/Output Terminals

-  **(USB) socket**

USB (1) for image data output with a personal computer

- **DC IN 3V (Power input) socket**

Socket for specified AC power adapter (optional)

## Power Supply and Others

- **Power supply**

Use one of the following:

- 2AA-size alkaline batteries
- 2AA-size Ni-MH (nickel-metal hydride) batteries (optional)
- AC Power Adapter AC-3V (optional)

- **No. of available shots using battery (battery life)**

Battery type	With LCD monitor ON	With LCD monitor OFF
Alkaline batteries	Approx. 150 frames	Approx. 200 frames
Ni-MH batteries HR-3UF 1700 mAh	Approx. 200 frames*	Approx. 300 frames*

(Condition: Power saving mode ON, with fully charged battery (Ni-MH))

This indicates the number of available frames shot consecutively at room temperature with a flash use rate of 50%. Note that these figures may vary depending on the ambient temperature and the amount of charge in the battery. The number of available shots or available shooting time will be lower in cold conditions.

- **Conditions for use**

Temperature: 0°C to +40°C (+32°F to +104°F); 80% humidity or less (no condensation)

- **Camera dimensions (W/H/D)**

97.0 mm × 63.9 mm × 34.3 mm/3.8 in. × 2.5 in. × 1.4 in. (not including accessories and attachments)

- **Camera mass (weight)**

Approx. 145 g/5.1 oz. (not including accessories, batteries or xD-Picture Card)

- **Weight for photography**

Approx. 200 g/7.1 oz. (including batteries and xD-Picture Card)

- **Accessories**

See P.7

- **Optional Accessories**

See P.106, 107

\* These specifications are subject to change without notice. FUJIFILM shall not be held liable for damages resulting from errors in this Owner's Manual.

\* The LCD monitor on your digital camera is manufactured using advanced high-precision technology. Even so, small bright points and anomalous colors (particularly around text) may appear on the monitor. These are normal display characteristics and do not indicate a fault with the monitor. This phenomenon will not appear on the recorded image.

\* The operation error may be caused in a digital camera by the strong radio interference (i. e. electric fields, static electricity, line noise, etc.).

\* Due to the nature of the lens, the edges of photographed images may appear distorted. This is normal and does not indicate a fault.

# Explanation of Terms

---

## **DPOF:** Digital Print Order Format

DPOF is a format used for recording information on a storage media (image memory card, etc.) that allows you to specify which of the frames shot using a digital camera are printed and how many prints are made of each image.

## **EV:**

A number that denotes exposure. The EV is determined by the brightness of the subject and sensitivity (speed) of the film or CCD. The number is larger for bright subjects and smaller for dark subjects. As the brightness of the subject changes, a digital camera maintains the amount of light hitting the CCD at a constant level by adjusting the aperture and shutter speed. When the amount of light striking the CCD doubles, the EV increases by 1. Likewise, when the light is halved, the EV decreases by 1.

## **JPEG:** Joint Photographics Experts Group

A file format used for compressing and saving color images. The compression ratio can be selected, but the higher the compression ratio, the poorer the quality of the expanded image.

## **Motion JPEG:**

A type of AVI (Audio Video Interleave) file format that handles images and sound as a single file. Images in the file are recorded in JPEG format. Motion JPEG can be played back by QuickTime 3.0 or later.

## **PC Card:**

A generic term for cards that meet the PC Card Standard.

## **PC Card Standard**

A standard for PC cards determined by the PCMCIA.

## **PCMCIA:**

Personal Computer Memory Card International Association (US).

## **White Balance:**

Whatever the kind of the light, the human eye adapts to it so that a white object still looks white. On the other hand, devices such as digital cameras see a white subject as white by first adjusting the color balance to suit the color of the ambient light around the subject. This adjustment is called matching the white balance. A function that automatically matches the white balance is called **an Automatic White Balance function**.

# Safety Notes

- To ensure that you use your FinePix A203/FinePix A303 camera correctly, read these Safety Notes and your Owner's Manual carefully beforehand.
- After reading these Safety Notes, store them in a safe place.

## About the Icons

The icons shown below are used in this document to indicate the severity of the injury or damage that can result if the information indicated by the icon is ignored and the product is used incorrectly as a result.



**WARNING** This icon indicates that death or serious injury can result if the information is ignored.



**CAUTION** This icon indicates that personal injury or material damage can result if the information is ignored.

The icons shown below are used to indicate the nature of the information which is to be observed.



Triangular icons notify the user of information requiring attention ("Important").



Circular icons with a diagonal bar notify the user that the action indicated is prohibited ("Prohibited").



Filled circles with an exclamation mark notify the user of an action that must be performed ("Required").



## WARNING

**When a fault arises, switch the camera off and then remove the batteries and disconnect the AC power adapter.**

Continued use of the camera when it is emitting smoke, is emitting any unusual odor, or is in any other abnormal state can cause a fire or electric shock.

- Contact your FUJIFILM dealer.



Unplug from power socket.

**Do not allow water or foreign objects to enter the camera.**

If water or foreign objects get inside the camera, switch the camera off, remove the battery and disconnect and unplug the AC power adapter.

Continued use of the camera can cause a fire or electric shock.

- Contact your FUJIFILM dealer.



**Do not place the camera on an unstable surface.**

This can cause the camera to fall or tip over and cause injury.



**Do not use the camera in the bathroom or shower.**

This can cause a fire or electric shock.



Do not use in the bathroom or shower.

# Safety Notes

## WARNING

**Never attempt to modify or disassemble the camera. (Never open the casing.)**

Do not use the camera when it has been dropped or the casing is damaged.

This can cause a fire or electric shock.

- Contact your FUJIFILM dealer.



Do not disassemble.

**Never attempt to take pictures while in motion.**

Do not use the camera while you are walking or operating a moving car or other vehicle.

This can result in you falling down or being involved in a traffic accident.



**Do not heat, modify or attempt to disassemble the batteries.**

**Do not drop or subject the batteries to impacts.**

**Do not attempt to recharge lithium or alkaline batteries.**

**Do not store the batteries with metallic products.**

Any of these actions can cause the batteries to burst or leak and cause fire or injury as a result.



## WARNING

**Do not touch any metal parts of the camera during a thunderstorm.**

This can cause an electric shock due to induced current from the lightning discharge.



**Do not use the batteries except as specified.**

Load the batteries with the poles positioned as indicated by the ⊕ and ⊖ marks.



**Use only the batteries or AC power adapter specified for use with this camera.**

The use of other power sources can cause a fire.



**If the battery leaks and fluid gets into your eyes or comes into contact with your skin or clothing, this can cause injury or loss of eyesight. Immediately flush the affected area thoroughly with clean water and seek medical treatment.**



**When discarding or storing batteries, cover the battery terminals with insulation tape.**

- Contact with other metallic objects or batteries could cause the batteries to ignite or burst.





## WARNING

### **Keep xD-Picture Cards out of the reach of small children.**

Because xD-Picture Cards are small, they can be accidentally swallowed by small children. Be sure to store xD-Picture Cards out of the reach of small children. If a child accidentally swallows an xD-Picture Card, seek medical advice immediately



## CAUTION

### **Keep out of the reach of small children.**

This product could cause injury in the hands of a child.



### **Do not use this camera in locations severely affected by oil fumes, steam, humidity or dust.**

This can cause a fire or electric shock.



### **Do not leave this camera in places subject to extremely high temperatures.**

Do not leave the camera in locations such as a sealed vehicle or in direct sunlight.

This can cause a fire.



### **Do not place heavy objects on the camera.**

This can cause the heavy object to tip over or fall and cause injury.



### **Do not move the camera while the AC power adapter is still connected.**

This can damage the power cord or cables and cause a fire or electric shock.



## Safety Notes



### CAUTION

**Do not cover or wrap the camera or the AC power adapter in a cloth or quilt.**

This can cause heat to build up and distort the casing or cause a fire.



**Remove the batteries and disconnect the AC power adapter when you are cleaning the camera or if you intend to leave the camera unused for a long period.**

Failure to do so can cause a fire or electric shock.



**Using a flash too close to a person's eyes may temporarily affect the eyesight.**

Take particular care when photographing infants and young children.



**When an xD-Picture Card is removed, the card may fly completely out of the slot. Use your finger to stop the card from flying out before removing the card.**

If an xD-Picture Card is allowed to fly out, it could hit someone and cause injury.



### CAUTION

**Request regular internal testing and cleaning for your camera.**

Build-up of dust in your camera can cause a fire or electric shock.

- Contact your FUJIFILM dealer to request internal cleaning every 2 years.



# EC Declaration of Conformity

---

We  
Name : Fuji Photo Film (Europe) G.m.b.H.  
Address : Heesenstrasse 31  
40549 Dusseldorf, Germany

declare that the product  
Product Name : FUJIFILM DIGITAL CAMERA FinePix A203/FinePix A303  
Manufacture's Name : Fuji Photo Film Co., Ltd.  
Manufacture's Address : 26-30, Nishiazabu 2-chome, Minato-ku,  
Tokyo 106-8620, Japan

is in conformity with the following Standards

Safety : EN60950  
EMC : EN55022 : 1998 Classe B  
EN55024 : 1998  
EN61000-3-2 : 1995 + A1:1998 + A2:1998

following the provision of the EMC Directive (89/336/EEC, 92/31/EEC and 93/68/EEC) and Low Voltage Directive (73/23/EEC).



Dusseldorf, Germany

September 1, 2002

Place

Date

Signature/Managing Director



Bij dit produkt zijn batterijen geleverd. Wanneer deze leeg zijn, moet u ze niet weggooien maar inleveren als KCA

## IMPORTANT

Be sure to read this page before using the Software.

## NOTICE

**BEFORE OPENING THE PACKAGE OF CD-ROM PROVIDED BY FUJI PHOTO FILM CO., LTD., PLEASE READ THIS END USER LICENSE AGREEMENT CAREFULLY. ONLY IF YOU DO AGREE TO THIS AGREEMENT, YOU WILL BE ABLE TO USE THE SOFTWARE RECORDED ON THE CD-ROM. BY OPENING THE PACKAGE, YOU ACCEPT AND AGREE TO BE BOUND BY THIS AGREEMENT.**

### End User License Agreement

This End User License Agreement ("Agreement") is an agreement between Fuji Photo Film Co., Ltd. ("FUJIFILM") and you, which sets forth the terms and conditions of the license granted for you to use the software provided by FUJIFILM.

The CD-ROM contains third party software. In case a separate agreement is provided by a third party supplier for its software, the provisions of such separate agreement shall apply to the use of such third party software, prevailing over those of this Agreement.

#### 1. Definitions.

- "Media" means the CD-ROM titled "Software for FinePix SX" which is provided to you together with this Agreement.
- "Software" means the software which is recorded on Media.
- "Documentation" means the operation manuals of Software and other related written materials which are provided to you together with Media.
- "Product" means Media (including Software) and Documentation collectively.

#### 2. Use of Software.

FUJIFILM grants to you a nontransferable, nonexclusive license:

- to install one copy of Software onto one computer in binary machine executable form;
- to use Software on the computer onto which Software is installed; and
- to make one backup copy of Software.

#### 3. Restrictions.

- 3.1 You shall not distribute, rent, lease or otherwise transfer all or any part of Software, Media or Documentation to any third party without FUJIFILM's prior written consent. You also shall not sublicense, assign or otherwise transfer all or any part of the rights granted to you by FUJIFILM under this Agreement without FUJIFILM's prior written consent.
- 3.2 Except as expressly granted by FUJIFILM hereunder, you shall not copy or reproduce all or any part of Software or Documentation.
- 3.3 You shall not modify, adapt or translate Software or Documentation. You also shall not alter or remove copyright and other proprietary notices that appear on or in Software or Documentation.
- 3.4 You shall not, or shall not have any third party, reverse-engineer, decompile, or disassemble Software.

#### 4. Ownership.

All copyrights and other proprietary rights to Software and Documentation are owned and retained by FUJIFILM or the third party suppliers as indicated on or in Software or Documentation. Nothing contained herein shall be construed, expressly or implicitly, as transferring or granting any right, license, or title to you other than those explicitly granted under this Agreement.

#### 5. Limited Warranty.

FUJIFILM warrants to you that Media is free from any defect in material and workmanship under normal use for ninety (90) days from the date of your receipt of Media. Should Media not meet the foregoing warranty, FUJIFILM shall replace such defective Media with other Media bearing no defect. FUJIFILM's entire liability and your sole and exclusive remedy with regard to any defect in Media shall be expressly limited to such FUJIFILM's replacement of Media as provided herein

#### 6. DISCLAIMER OF WARRANTY.

EXCEPT AS PROVIDED IN SECTION 5 HEREIN, FUJIFILM PROVIDES PRODUCT "AS IS" AND WITHOUT WARRANTIES OF ANY KIND, EXPRESS OR IMPLIED. FUJIFILM SHALL MAKE NO WARRANTY, EXPRESS, IMPLIED OR STATUTORY, AS TO ANY OTHER MATTERS, INCLUDING, BUT NOT LIMITED TO NON-INFRINGEMENT OF ANY COPYRIGHT, PATENT, TRADE SECRET, OR ANY OTHER PROPRIETARY RIGHTS OF ANY THIRD PARTY, MERCHANTABILITY, OR FITNESS FOR ANY PARTICULAR PURPOSE.

#### 7. LIMITATION OF LIABILITY.

IN NO EVENT SHALL FUJIFILM HAVE ANY LIABILITY FOR ANY GENERAL, SPECIAL, DIRECT, INDIRECT, CONSEQUENTIAL, INCIDENTAL, OR OTHER DAMAGES (INCLUDING DAMAGES FOR LOSS OF PROFITS OR LOST SAVINGS) INCURRED FROM THE USE OF OR INABILITY TO USE PRODUCT EVEN IF FUJIFILM HAS BEEN ADVISED OF THE POSSIBILITY OF SUCH DAMAGES.

#### 8. No export.

You acknowledge that neither Software nor any part thereof, will be transferred, or exported to any country or used in any manner in violation of any export control laws and regulations to which Software is subject.

#### 9. Termination.

In case you breach any of the terms and conditions hereof, FUJIFILM may immediately terminate this Agreement without any notice.

#### 10. Term.

This Agreement is effective until the date when you cease to use Software, unless earlier terminated in accordance with Section 9 hereof.

#### 11. Obligation upon termination.

Upon termination or expiration of this Agreement, you shall, at your own responsibility and expense, delete or destroy immediately all Software (including its copies), Media and Documentation.

#### 12. Governing Law.

This Agreement shall be governed by and construed in accordance with laws of Japan.





**FUJI PHOTO FILM CO., LTD.**

26-30, Nishiazabu 2-chome, Minato-ku, Tokyo 106-8620, Japan

Printed in Japan



Printed on recycled paper.

FGS-204107-FG